

 <p>tecnobanc ARREDAMENTI FRIGORIFERI</p> <p>VIA DEL PIANO S.N. 61022 TALACCHIO DI COLBORDOLO PESARO ITALY TEL. 0721.478443 FAX. 0721.479306</p>		<p>INFO@TECNOBANC.IT</p> <p>WEB: TECNOBANC.IT TECNOBANC.COM</p>
--	--	---

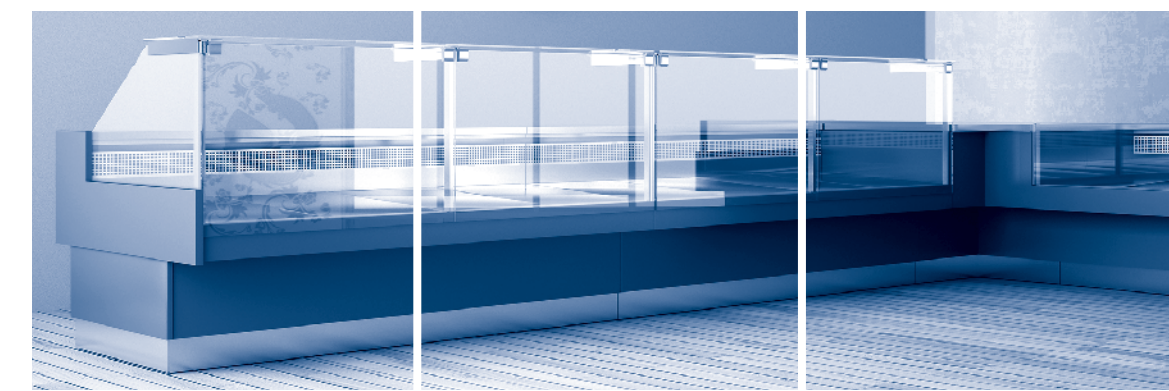

A R A





S
H
O
W
C
A
S
E
P
R
O
G
R
A
M





FLEXIBILITY

ARA DSV - CONTACT

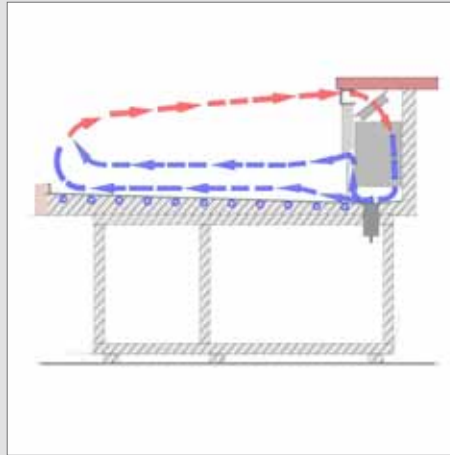

ARA DSV

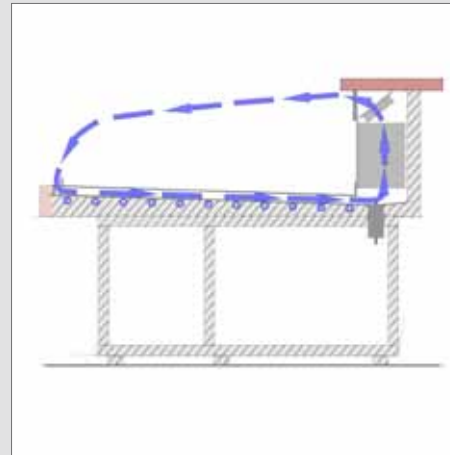

ARA DS

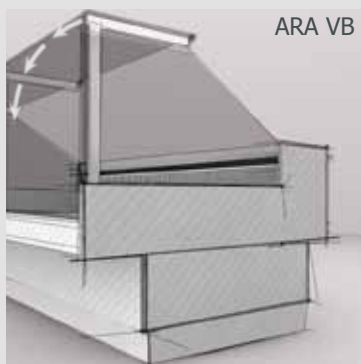
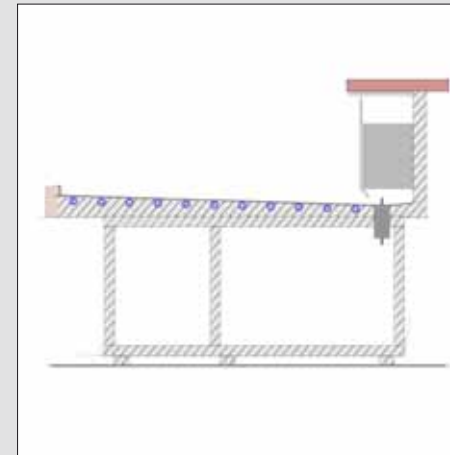

ARA VB

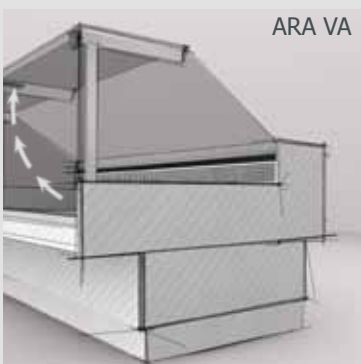

ARA VA

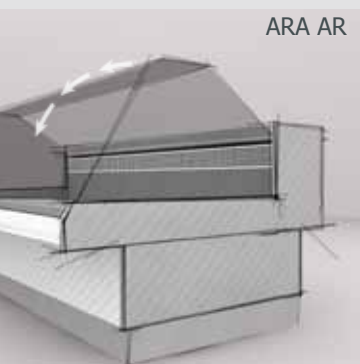

ARA AR

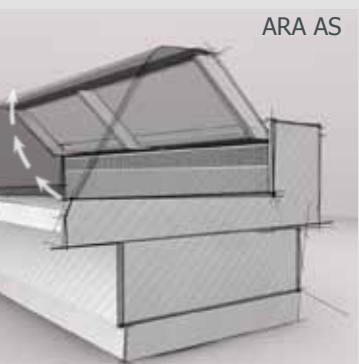

ARA AS



ARA HR

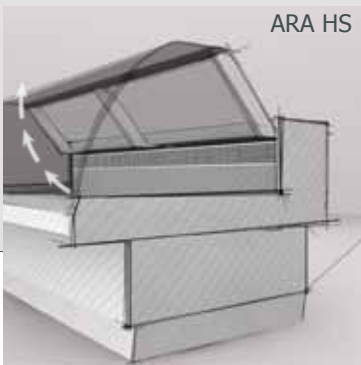

ARA HS

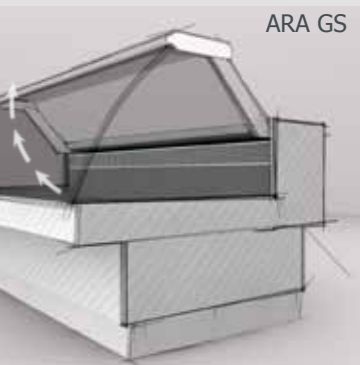

ARA GS

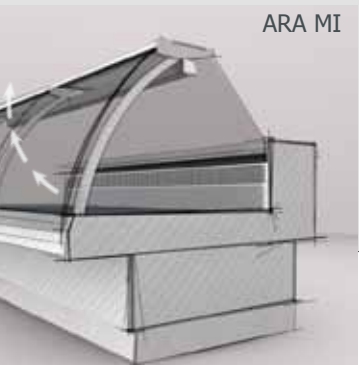

ARA MI





CARATTERISTICHE STANDARD:

- Struttura interna ed esterna costruita in acciaio AISI 304 coibentata con poliuretano;
- Controllo elettronico di tutte le funzioni con display digitale;
- Regolatori velocità ventole;

STANDARD CHARACTERISTICS:

- Internal and external structure in AISI 304 Stainless Steel injected with polyurethane;
- Electronic control of all functions with digital display;
- Fan speed controls;

STANDARD EIGENSCHAFTEN:

- Innen und außen aus Edelstahl AISI 304 isoliert mit Polyurethan;
- Elektronische Steuerung aller Betriebe mit digitalem Display;
- Lüfter Regler;

AMÉNAGEMENT STANDARD:

- Structure interne et externe en acier AISI 304 isolée avec polyuréthane;
- Contrôle électronique de toutes fonctions avec display digital;
- Régulateur vitesse ventilateurs;



CARATTERISTICHE STANDARD:

- Piano lavoro in acciaio inox satinato;
- Portacarte su tutta la lunghezza;
- Scarichi a "V" con tubi saldati per garantire il totale deflusso dell'acqua di sbrinamento e/o lavaggio;

STANDARD CHARACTERISTICS:

- Work shelf in brushed stainless steel;
- Paper holders for entire length;
- "V" shaped drains with welded water outlet pipes to guarantee the complete outflow of defrost and/or washing water;

STANDARD EIGENSCHAFTEN:

- Arbeitsplatte aus CNS satiniert;
- Papiertasche bei ganzer Länge;
- "V" Abflüsse mit geschweißten Rohre, um den völligen Abfluss vom Entfrosts- und/oder Reinigungswasser zu versichern

AMÉNAGEMENT STANDARD:

- Tablette de service en acier inoxydable satiné;
- Porte-papier sur toute la longueur;
- Ecoulements à "V" avec tubes soudés pour garantir la sortie totale de l'eau de dégivrage et/ou lavage;



PARTI DA SCEGLIERE:

- Vetro frontale;
- Illuminazione: Neon o LED;
- Spalle: inox o laminate;

PARTS TO CHOOSE :

- Front glasses;
- Lighting: Neon or LED;
- Side panels: stainless steel or laminate;

ZUM WÄHLEN:

- Frontglas;
- Beleuchtung : Neon oder LED;
- Seitenwände : aus CNS oder aus laminat;

A CHOISIR :

- Vitre frontal;
- Eclairage : néon ou LED;
- Jous : en inox ou laminat;

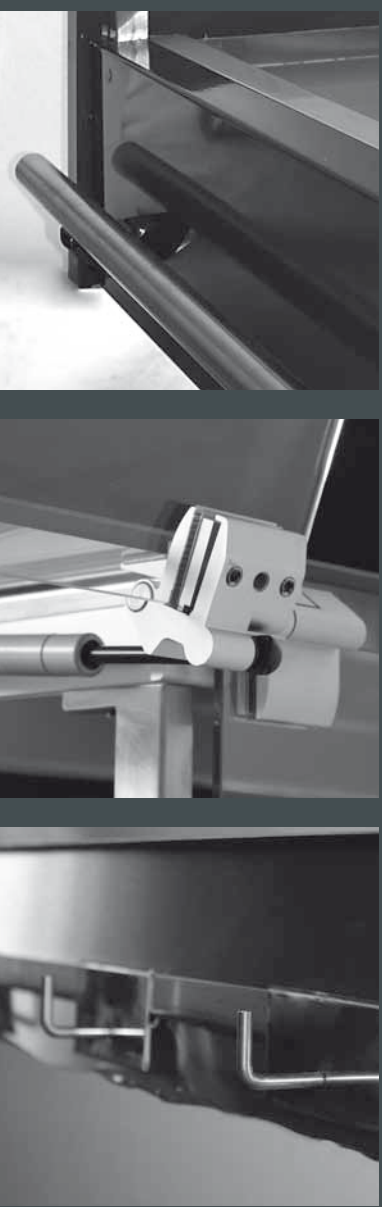

PARTI DA SCEGLIERE:

- Pannelli frontali superiore e inferiore : laminato o verniciato;
- ACCESSORI A RICHIESTA

PARTS TO CHOOSE :

- Upper and lower front panels: laminate or painted;
- ACCESSORIES ON REQUEST

ZUM WÄHLEN:

- Oberes und unteres Frontpaneel: beschichtet oder Laminat;
- ZUBEHÖR NACH WUNSCH

A CHOISIR :

- Panneau frontal supérieure et inférieure : laqué ou en laminat;
- ACCESSOIRES SUR DEMANDE

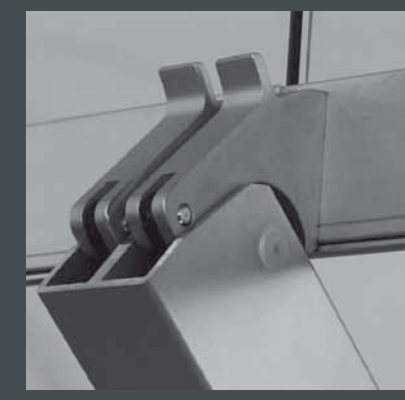
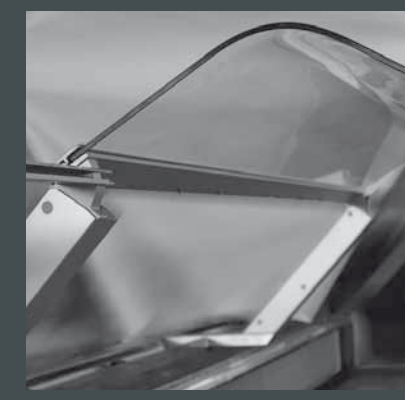
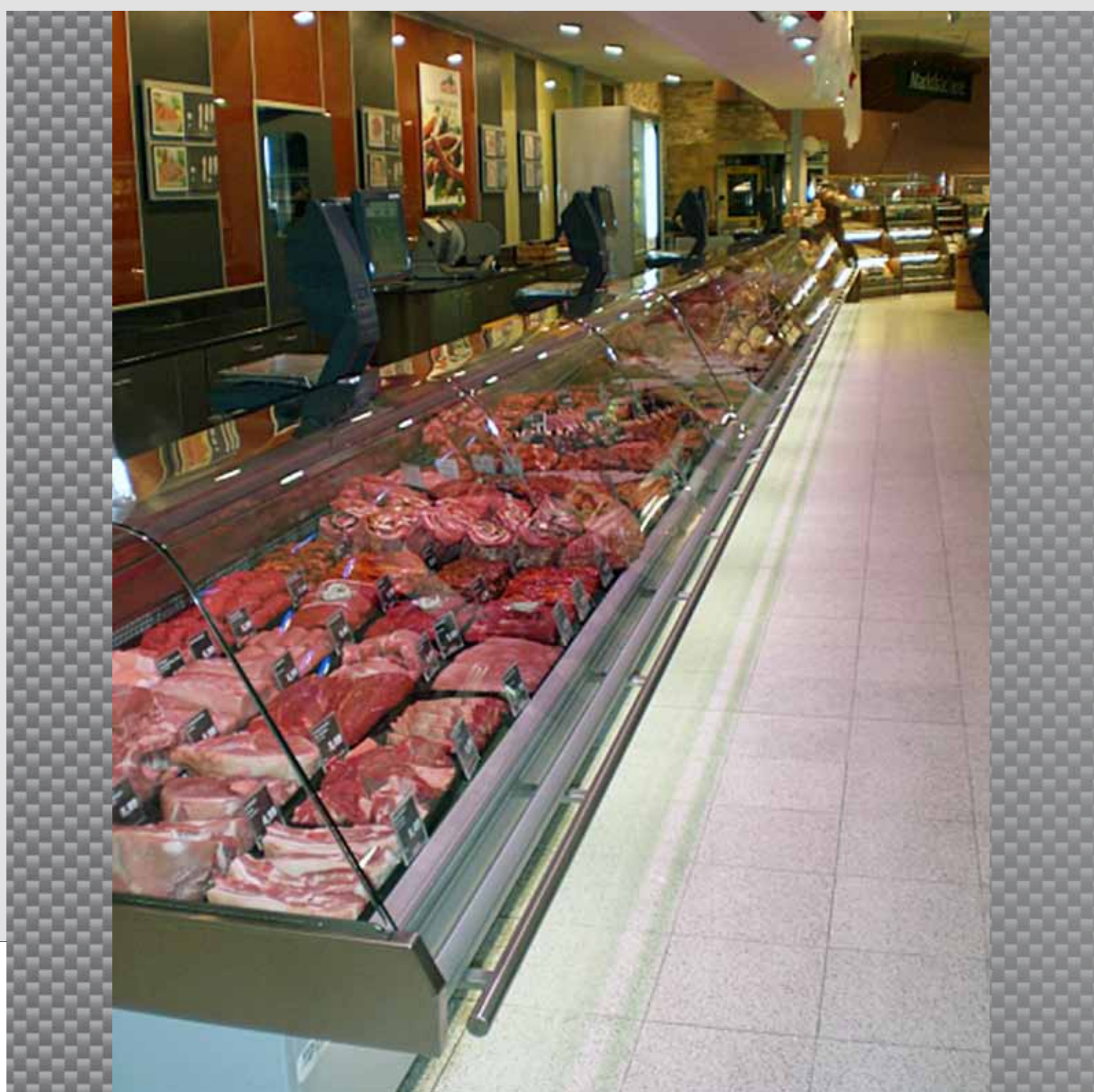

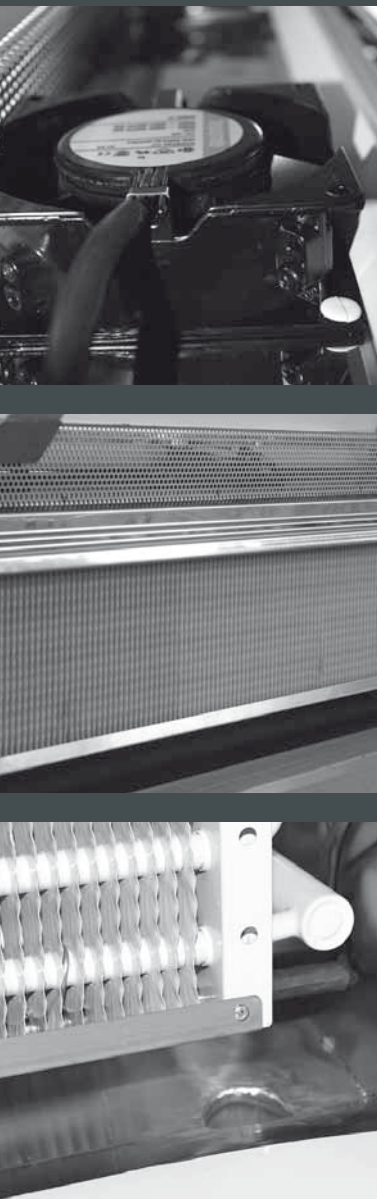

TECNOLOGIA

DATI TECNICI - TECHNICAL DATA	UNITA' - UNIT	100	125	150	200	250	300	320	350	375	400
TECHNISCHE DATEN - DONNÉES TECHNIQUES	EINHEIT - UNITE										
Lunghezze senza spalle Lengths without side panels Längen ohne Seitenwände Longueurs sans joues	mm	947	1247	1447	1894	2494	2894	3141	3441	3741	3941
Capacità frigorifera evaporatore Evaporator cooling capacity Kühlungsfähigkeit des Verdampfer s Capacité frigorifique évaporateur	W	276	370	420	560	730	850	920	1010	1090	1150
Capacità frigorifera piano Cooling capacity of refrigerated plate Kühlungsfähigkeit der Kühlplatte Capacité frigorifique plaque réfrigérée	W	140	180	205	270	350	410	440	490	530	560
Area espositiva Display area Auslagefläche Exposition	mq.	0,834	1,1	1,274	1,667	2,195	2,574	2,765	3,029	3,293	3,469
Espansione DSV- CONTACT : Evaporatore/Piano Expansion temperature DSV- CONTACT: Evaporator /refrigerated plate Expansionstemperatur DSV- CONTACT : Verdampfer/ Kühlplatte Température d'expansion DSV- CONTACT: Evaporateur/ plaque réfrigérée	°C	-8°/-3°	-8°/-3°	-8°/-3°	-8°/-3°	-8°/-3°	-8°/-3°	-8°/-3°	-8°/-3°	-8°/-3°	-8°/-3°
Espansione DSV : Evaporatore/Piano Expansion temperature DSV: Evaporator /refrigerated plate Expansionstemperatur DSV: Verdampfer/ Kühlplatte Température d'expansion DSV : Evaporateur/Plaque réfrigérée	°C	-10°/-3°	-10°/-3°	-10°/-3°	-10°/-3°	-10°/-3°	-10°/-3°	-10°/-3°	-10°/-3°	-10°/-3°	-10°/-3°
Espansione DS : Evaporatore/Piano Expansion temperature DS : Evaporator /refrigerated plate Expansionstemperatur DS : Verdampfer/ Kühlplatte Température d'expansion DS : Evaporateur/Plaque réfrigérée	°C	-10°/-3°	-10°/-3°	-10°/-3°	-10°/-3°	-10°/-3°	-10°/-3°	-10°/-3°	-10°/-3°	-10°/-3°	-10°/-3°

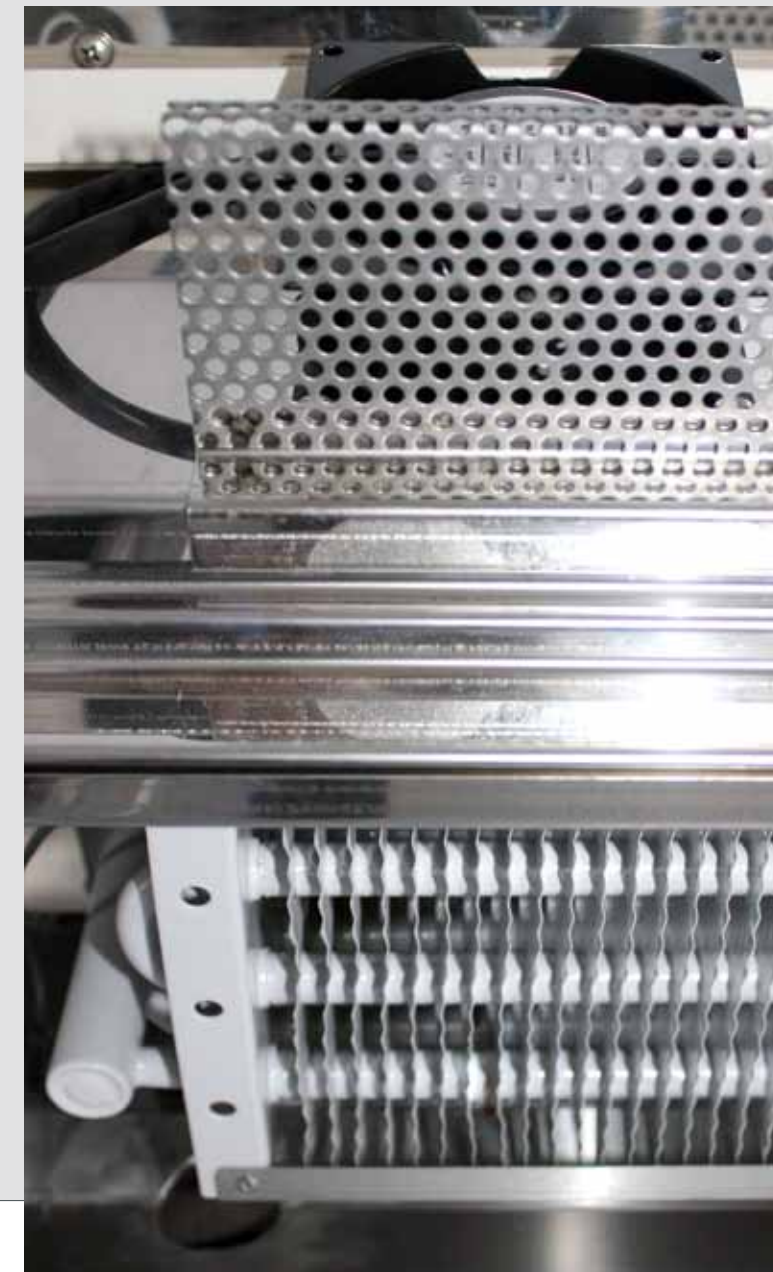



SEZIONI

Section drawings

Schnitzzeichnungen

Dessins des coupes

ARA HS

Vetri panorama bombati apribili verso alto
Rounded panorama glasses opening upwards
Gewölbte Panorama Scheiben-Öffnung nach oben
Vitres bombés panorama relevables

ARA DSV-C
Doppio Statico Ventilato-Contact
Double Static Ventilated-Contact
Double Statique Ventilée-Contact
Doppelt Statische Umluft kühlung-Contact

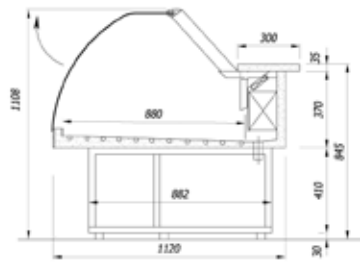

ARA DSV
Doppio Statico Ventilato
Double Static Ventilated
Double Statique Ventilée
Doppelt Statische Umluft kühlung

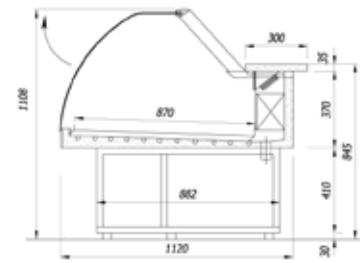

ARA DS
Doppio Statico
Double Static
Double Statique
Doppelt Statische

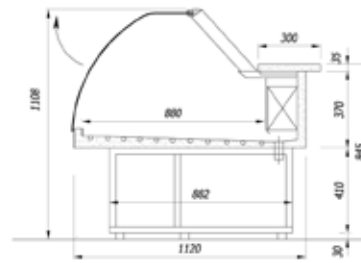

ARA HR

Vetri panorama bombati apribili verso basso
Rounded panorama glasses opening downwards
Gewölbte Scheiben kippbar nach unten
Vitres bombés panorama basculants

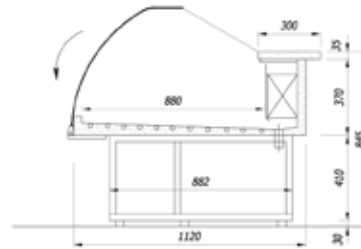
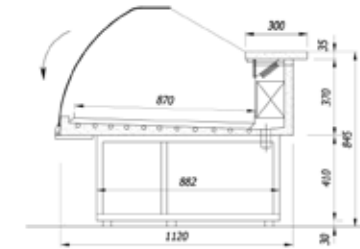
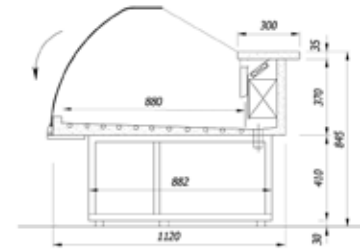

ARA VB

Vetri diritti verticali apribili verso basso
Vertical straight glasses opening downwards
Vertikale gerade Scheiben kippbar nach unten
Vitres droits verticaux basculants

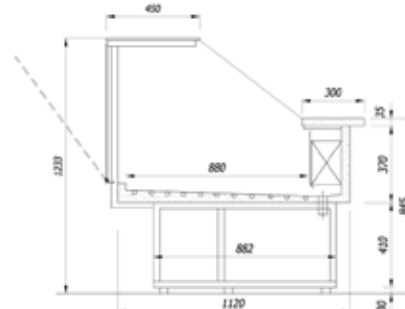
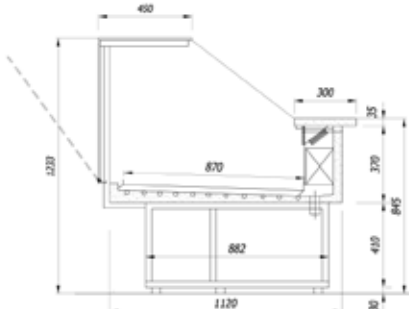
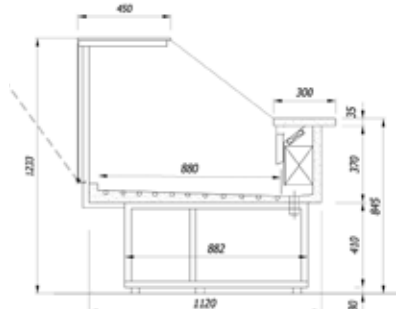

ARA VA

Vetri diritti verticali apribili verso alto
Vertical straight glasses opening upwards
Vertikale gerade Scheiben - Öffnung nach oben
Vitres droits verticaux relevables

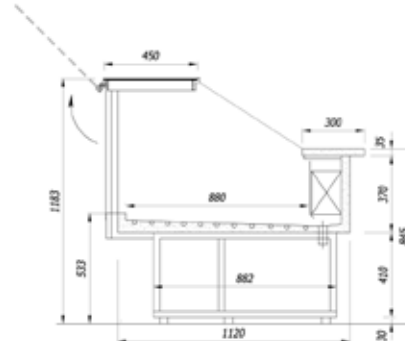
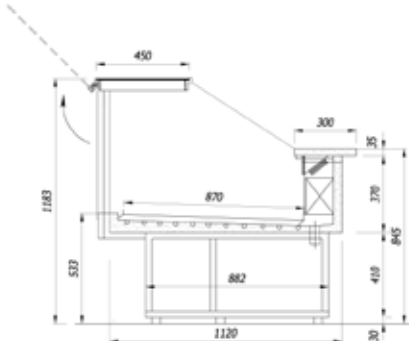
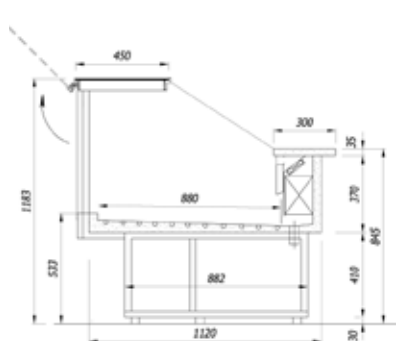

SEZIONI

Section drawings

Schnitzzeichnungen

Dessins des coupes

ARA AS

Vetri panorama apribili verso alto
Curved panorama glasses opening upwards
Gebogene Panorama Scheiben - Öffnung nach oben
Vitres bombés - droits panorama relevables

ARA DSV-C
Doppio Statico Ventilato-Contact
Double Static Ventilated-Contact
Double Statique Ventilée-Contact
Doppelt Statische Umluft kühlung-Contact

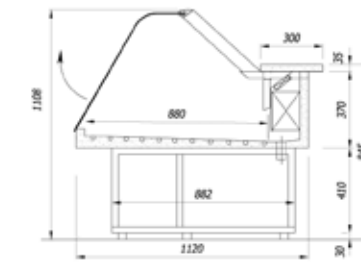

ARA DSV
Doppio Statico Ventilato
Double Static Ventilated
Double Statique Ventilée
Doppelt Statische Umluft kühlung

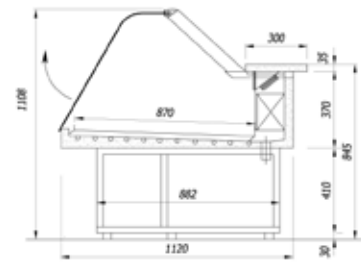

ARA DS
Doppio Statico
Double Static
Double Statique
Doppelt Statische

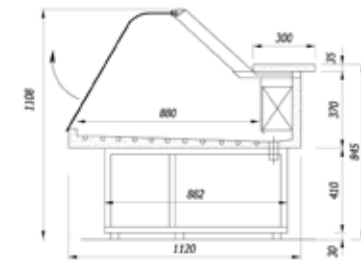

ARA AR

Vetri panorama apribili verso basso
Curved panorama glasses opening downwards
Gebogene Panorama Scheiben kippbar nach unten
Vitres bombés - droits panorama basculants

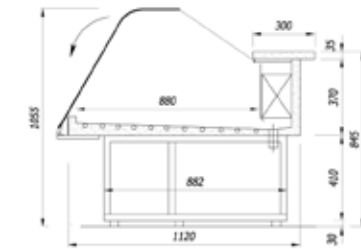
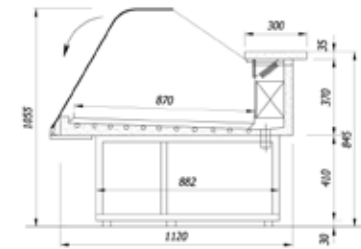
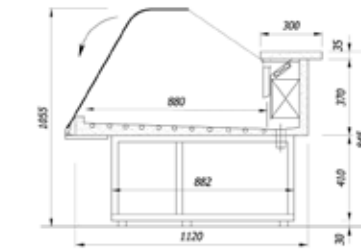

ARA MI

Vetri curvi apribili verso alto con struttura frontale e pianetto
Curved glasses opening upwards with front supports and canopy
Gebogene Scheiben mit Frontstützen und Zahlplatte - Öffnung nach oben
Vitres bombés relevables avec structure frontale et tablette vitre fixe

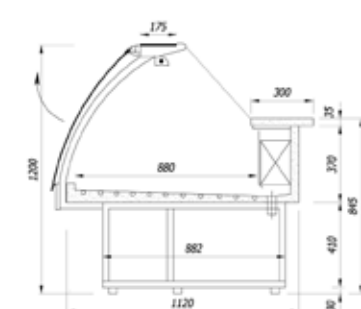
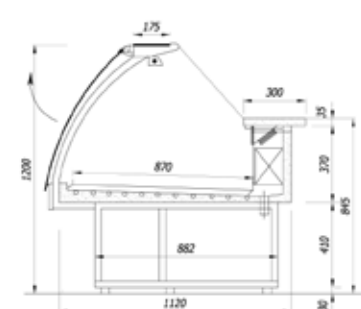
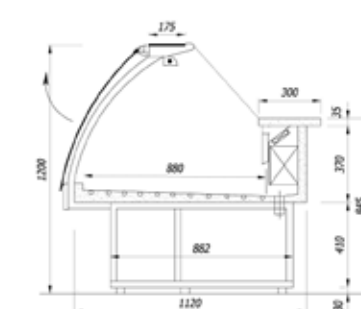

ARA GS

Vetri curvi apribili verso alto con pianetto
Curved panorama glasses opening upwards with glass canopy
Gebogene Panorama Scheiben mit Glas Zahlplatte - Öffnung nach oben
Vitres bombés-droits panorama relevables avec tablette vitre fixe

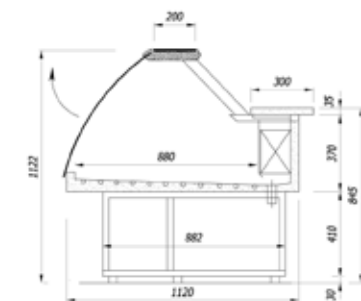
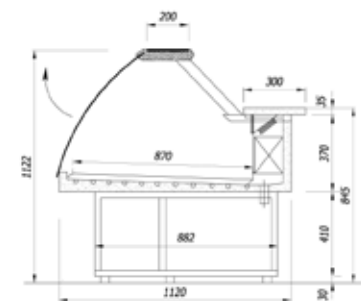
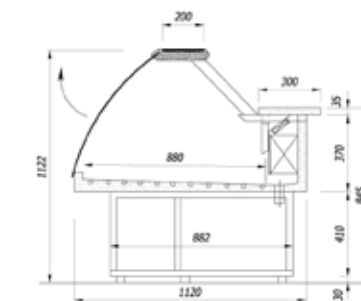

 <p>tecnobanc ARREDAMENTI FRIGORIFERI</p> <p>VIA DEL PIANO S.N. 61022 TALACCHIO DI COLBORDOLO PESARO ITALY TEL. 0721.478443 FAX. 0721.479306</p>		<p>INFO@TECNOBANC.IT</p> <p>WEB: TECNOBANC.IT TECNOBANC.COM</p>
--	--	---

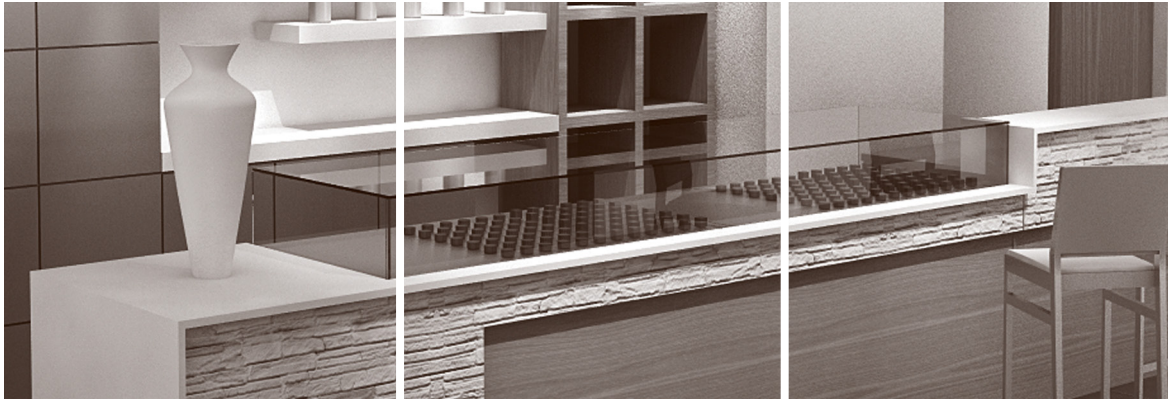

D R O P - I N





VIA DEL PIANO
S.N.61022 TALACCHIO
DI COLBORDOLO
PESARO
ITALY
TEL. 0721.478443
FAX. 0721.479306



INFO@TECNOBANC.IT

WEB:
TECNOBANC.IT
TECNOBANC.COM

DROP-IN



tecnobanc
ARREDAMENTI FRIGORIFERI



BQ 550 Vasca incassata

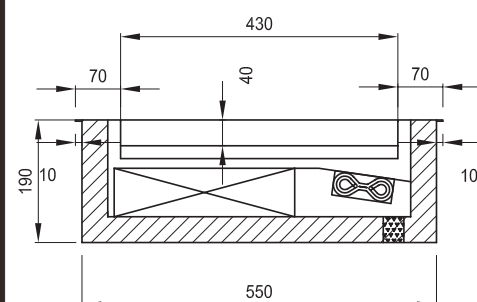

NETTO MISURE mm	VE-TRI Nr.	ESPOSIZIONE AREA	
		Temp.°C	M ²
947	1	0°/+2°	0,75
1247	1	0°/+2°	0,99
1447	1	0°/+2°	1,15
1894	2	0°/+2°	1,51
2494	2	0°/+2°	1,99
2894	2	0°/+2°	2,31
3441	3	0°/+2°	2,74
3941	3	0°/+2°	3,14

BQ Vasca incassata

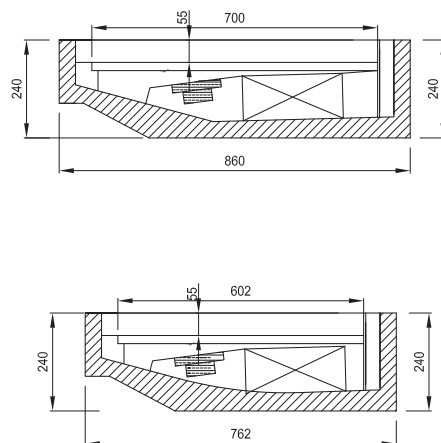
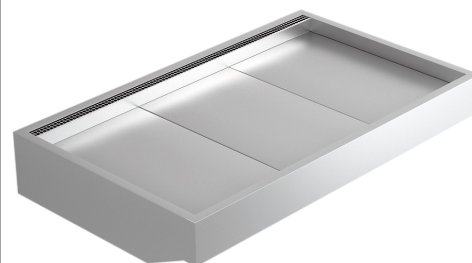

NETTO MISURE mm	VE-TRI Nr.	ESPOSIZIONE AREA	
		Temp.°C	M ²
947	1	0°/+2°	0,75
1247	1	0°/+2°	0,99
1447	1	0°/+2°	1,15
1894	2	0°/+2°	1,51
2494	2	0°/+2°	1,99
2894	2	0°/+2°	2,31
3441	3	0°/+2°	2,74
3941	3	0°/+2°	3,14

BQ Vasca piatta

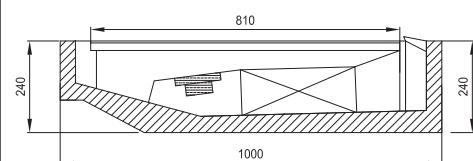

NETTO MISURE mm	VE-TRI Nr.	ESPOSIZIONE AREA	
		Temp.°C	M ²
947	1	0°/+2°	0,75
1247	1	0°/+2°	0,99
1447	1	0°/+2°	1,15
1894	2	0°/+2°	1,51
2494	2	0°/+2°	1,99
2894	2	0°/+2°	2,31
3441	3	0°/+2°	2,74
3941	3	0°/+2°	3,14

BQ Rialzabile piatta

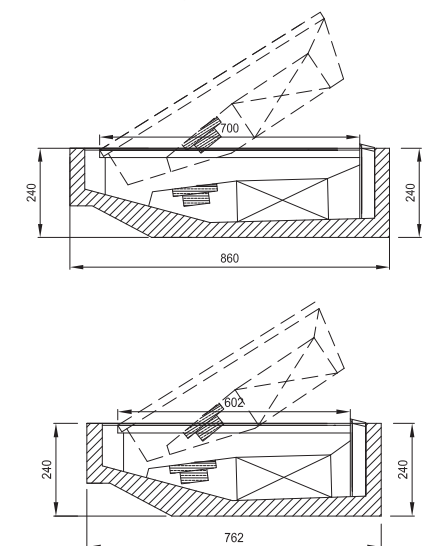

NETTO MISURE mm	VE-TRI Nr.	ESPOSIZIONE AREA	
		Temp.°C	M ²
947	1	0°/+2°	0,75
1247	1	0°/+2°	0,99
1447	1	0°/+2°	1,15
1894	2	0°/+2°	1,51
2494	2	0°/+2°	1,99
2894	2	0°/+2°	2,31
3441	3	0°/+2°	2,74
3941	3	0°/+2°	3,14

BQ Rialzabile incassata

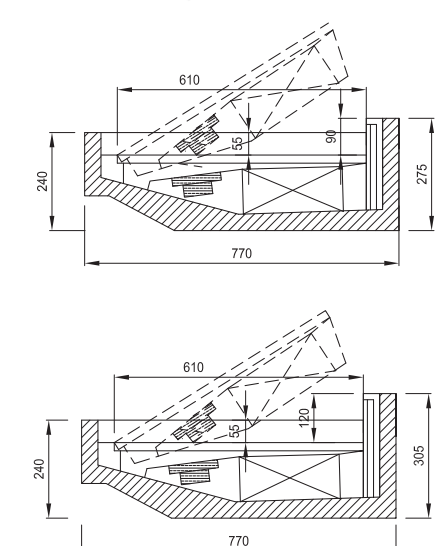

NETTO MISURE mm	VE-TRI Nr.	ESPOSIZIONE AREA	
		Temp.°C	M ²
947	1	0°/+2°	0,75
1247	1	0°/+2°	0,99
1447	1	0°/+2°	1,15
1894	2	0°/+2°	1,51
2494	2	0°/+2°	1,99
2894	2	0°/+2°	2,31
3441	3	0°/+2°	2,74
3941	3	0°/+2°	3,14

BQ calda vasche separate

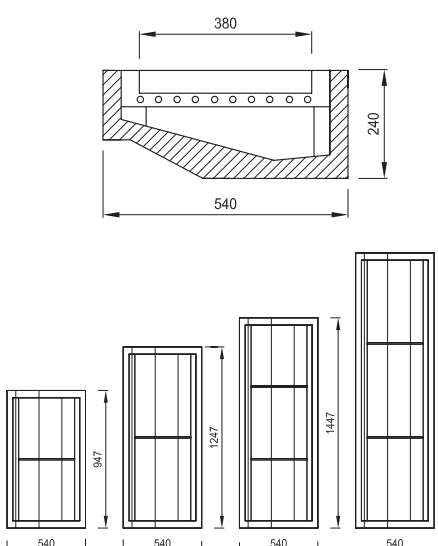
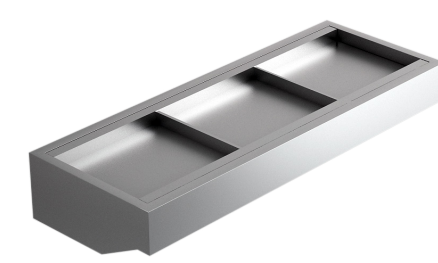

NETTO MISURE mm	VE-TRI Nr.	ESPOSIZIONE AREA	
		Temp.°C	M ²
947	1	0°/+2°	0,75
1247	1	0°/+2°	0,99
1447	1	0°/+2°	1,15
1894	2	0°/+2°	1,51
2494	2	0°/+2°	1,99
2894	2	0°/+2°	2,31
3441	3	0°/+2°	2,74
3941	3	0°/+2°	3,14

BQ riscaldata vetroceramica

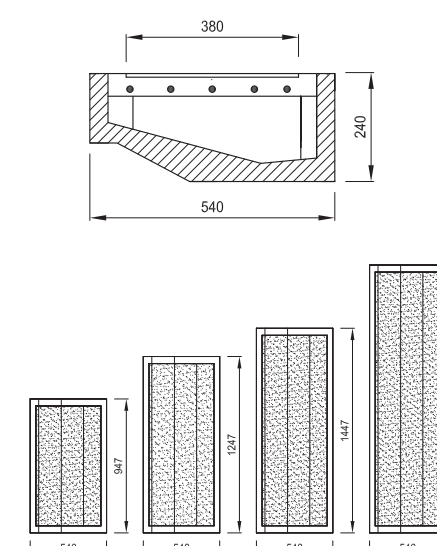

NETTO MISURE mm	VE-TRI Nr.	ESPOSIZIONE AREA	
		Temp.°C	M ²
947	1	0°/+2°	0,75
1247	1	0°/+2°	0,99
1447	1	0°/+2°	1,15
1894	2	0°/+2°	1,51
2494	2	0°/+2°	1,99
2894	2	0°/+2°	2,31
3441	3	0°/+2°	2,74
3941	3	0°/+2°	3,14

BQ riscaldata piastre inox

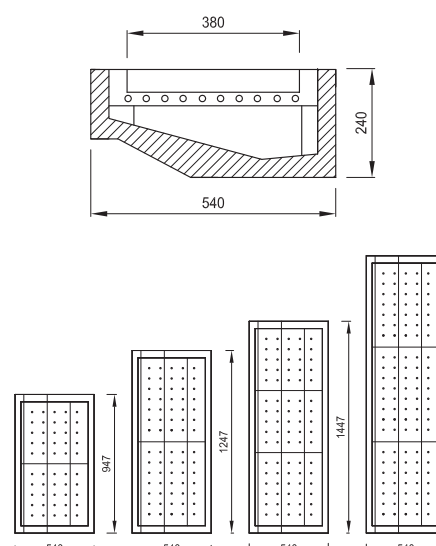

NETTO MISURE mm	VE-TRI Nr.	ESPOSIZIONE AREA	
		Temp.°C	M ²
947	1	0°/+2°	0,75
1247	1	0°/+2°	0,99
1447	1	0°/+2°	1,15
1894	2	0°/+2°	1,51
2494	2	0°/+2°	1,99
2894	2	0°/+2°	2,31
3441	3	0°/+2°	2,74
3941	3	0°/+2°	3,14

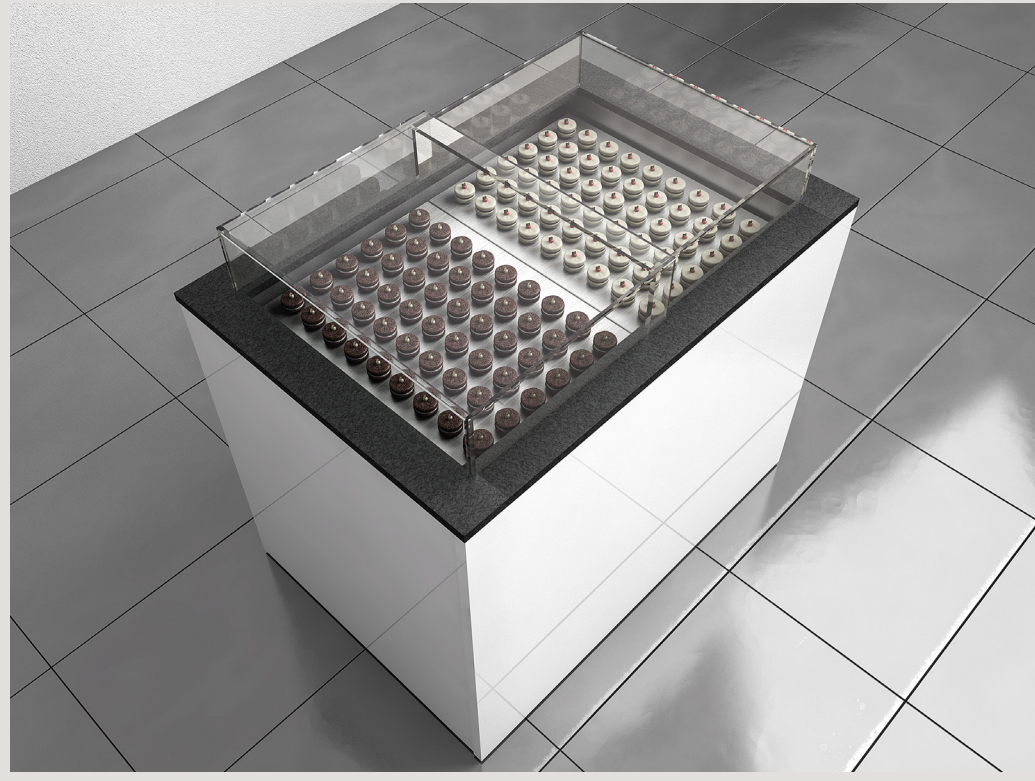

tecnobanc
ARREDAMENTI FRIGORIFERI

VIA DEL PIANO S.N.
61022 TALACCHIO
DI COLBORDOLO
PESARO
ITALY
TEL. 0721.478443
FAX. 0721.479306

 <p>Via del piano s.n. 61022 Talacchio di Colbordolo Pesaro Italy Tel. 0721.478443 Fax. 0721.479306</p>		<p>info@tecnobanc.it</p> <p>web: tecnobanc.it tecnobanc.com tecnobanc-austria.at</p>
--	--	--



LIBRA





prova di composizione del testo in un ambito poligonale di sei lati asdfasdf fasdkj a fasdkkj asdfklaòsf asdf lkscdj òlksdj sa dsfasld kjsdlf j dfkaslf asf sf sdf sdj slckf jsf sdfksjdfasfasdfòlsòd lfkjaòsdjkrfaòsljdfraòsdfjòasdjkròalsdjkr

prova di composizione del testo in un ambito poligonale di sei lati asdfasdf fasdkj a fasdkkj asdfklaòsf asdf lkscdj òlksdj sa dsfasld kjsdlf j dfkaslf asf sf sdf sdj slckf jsf sdfksjdfasfasdfòlsòd lfkjaòsdjkrfaòsljdfraòsdfjòasdjkròalsdjkr

prova di composizione del testo in un ambito poligonale di sei lati asdfasdf fasdkj a fasdkkj asdfklaòsf asdf lkscdj òlksdj sa dsfasld kjsdlf j dfkaslf asf sf sdf sdj slckf jsf sdfksjdfasfasdfòlsòd lfkjaòsdjkrfaòsljdfraòsdfjòasdjkròalsdjkr

prova di composizione del testo in un ambito poligonale di sei lati asdfasdf fasdkj a fasdkkj asdfklaòsf asdf lkscdj òlksdj sa dsfasld kjsdlf j dfkaslf asf sf sdf sdj slckf jsf sdfksjdfasfasdfòlsòd lfkjaòsdjkrfaòsljdfraòsdfjòasdjkròalsdjkr

prova di composizione del testo in un ambito poligonale di sei lati asdfasdf fasdkj a fasdkkj asdfklaòsf asdf lkscdj òlksdj sa dsfasld kjsdlf j dfkaslf asf sf sdf sdj slckf jsf sdfksjdfasfasdfòlsòd lfkjaòsdjkrfaòsljdfraòsdfjòasdjkròalsdjkr

prova di composizione del testo in un ambito poligonale di sei lati asdfasdf fasdkj a fasdkkj asdfklaòsf asdf lkscdj òlksdj sa dsfasld kjsdlf j dfkaslf asf sf sdf sdj slckf jsf sdfksjdfasfasdfòlsòd lfkjaòsdjkrfaòsljdfraòsdfjòasdjkròalsdjkr

prova di composizione del testo in un ambito poligonale di sei lati asdfasdf fasdkfj a fasdkkf asdfklaðsf asdf lkcsdj òlksdj sa dsfasld kfjsdlf j dtkaslif asf sf sdf sdj slakf jef sdflksjdfasfa-sdfòljsòdlfkjaòsdjkrfaòsljdfaòsdjfoasdjkròalsdjkrf

prova di composizione del testo in un ambito poligonale di sei lati asdfasdf fasdkfj a fasdkkf asdfklaðsf asdf lkcsdj òlksdj sa dsfasld kfjsdlf j dtkaslif asf sf sdf sdj slakf jef sdflksjdfasfasd-fòljsòdlfkjaòsdjkrfaòsljdfaòsdjfoasdjkròalsdjkrf

prova di composizione del testo in un ambito poligonale di sei lati asdfasdf fasdkfj a fasdkkf asdfklaðsf asdf lkcsdj òlksdj sa dsfasld kfjsdlf j dtkaslif asf sf sdf sdj slakf jef sdflksjdfasfasd-fòljsòdlfkjaòsdjkrfaòsljdfaòsdjfoasdjkròalsdjkrf

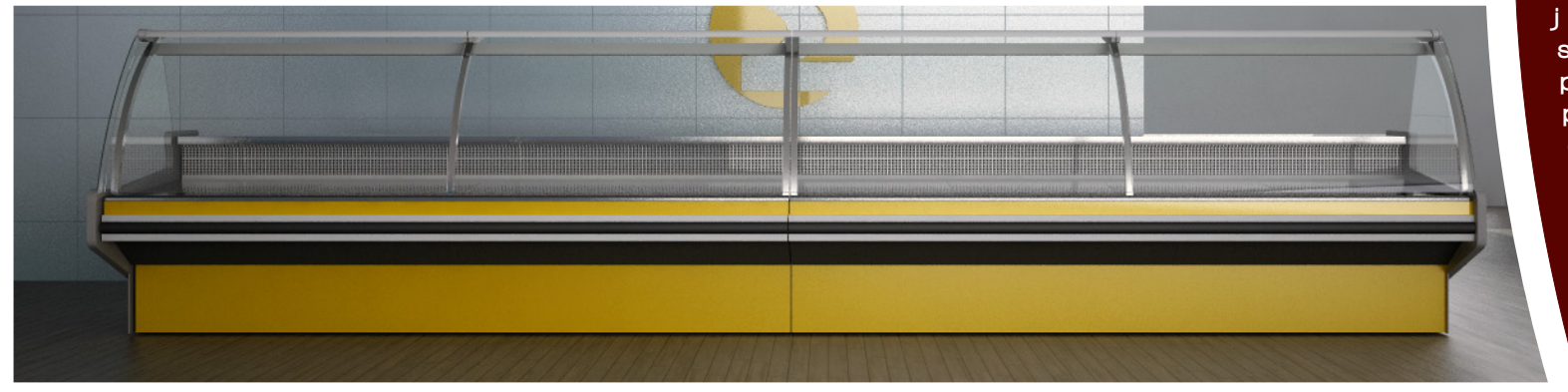
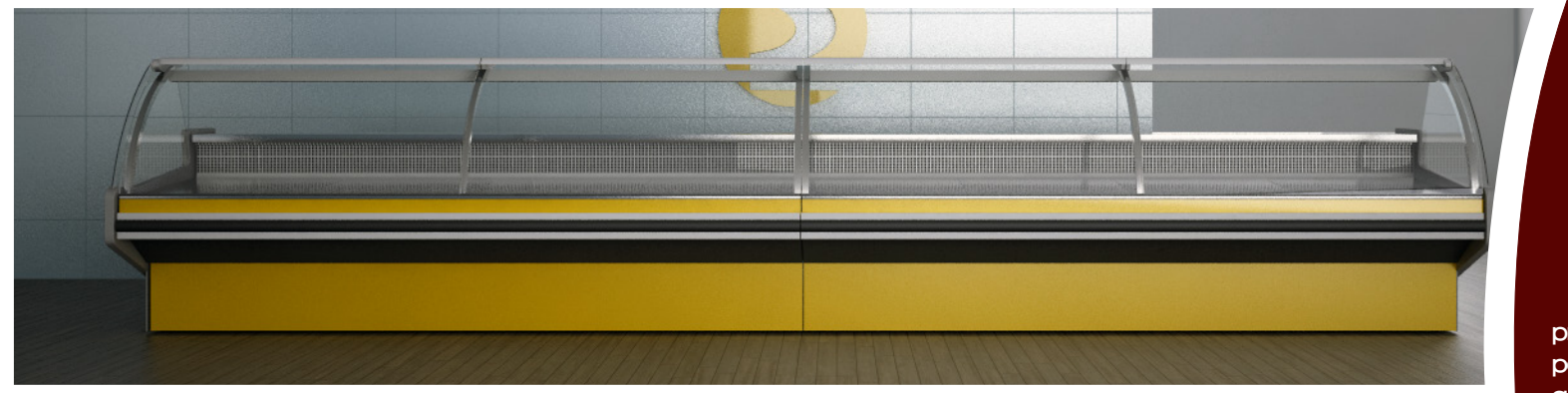
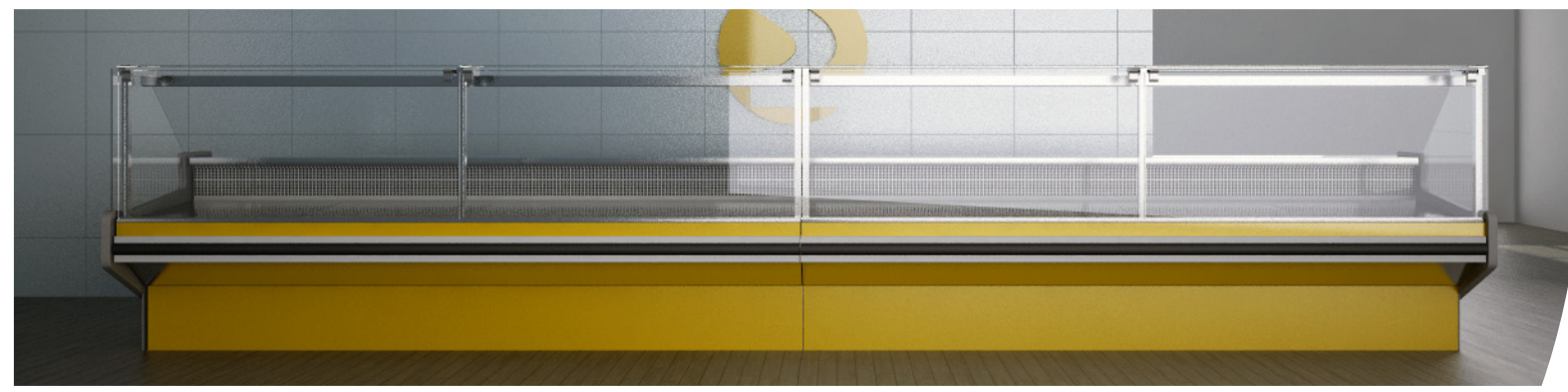
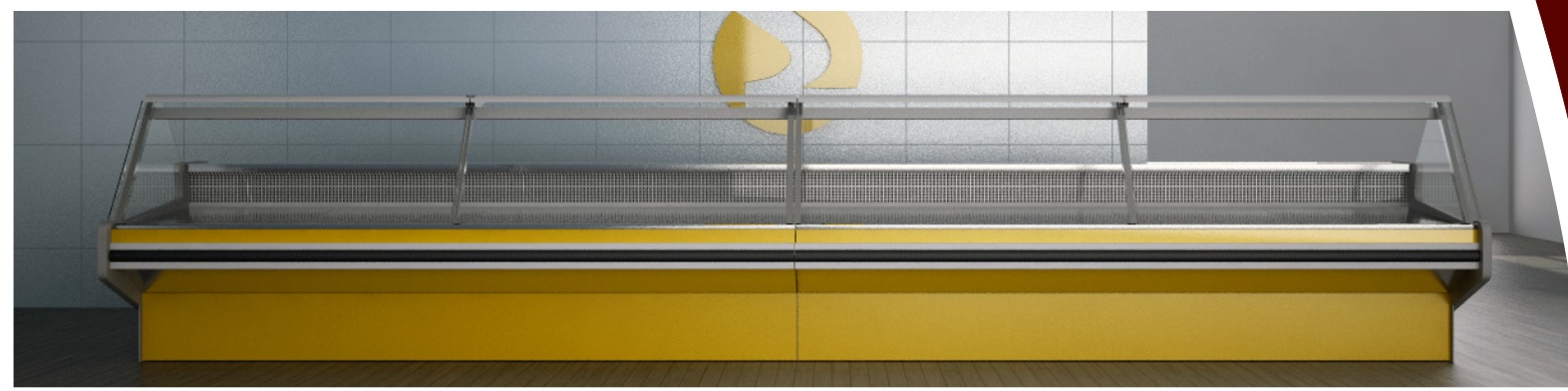
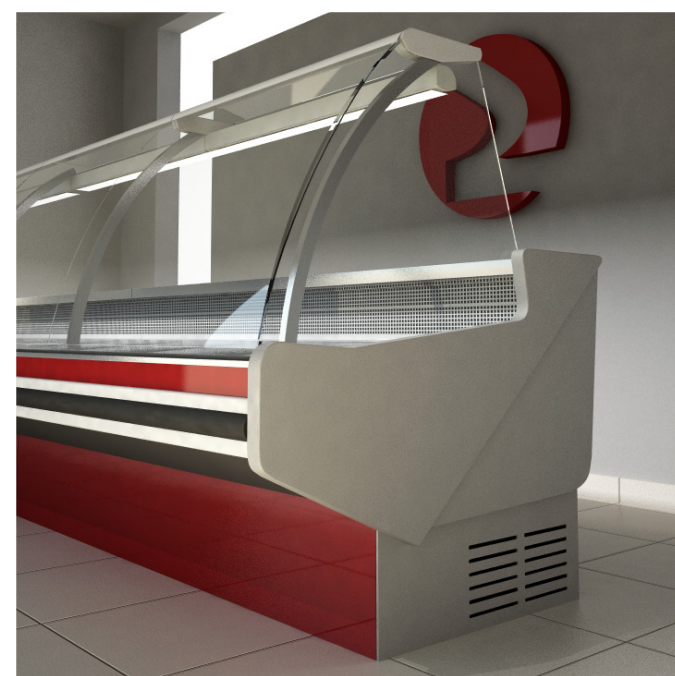
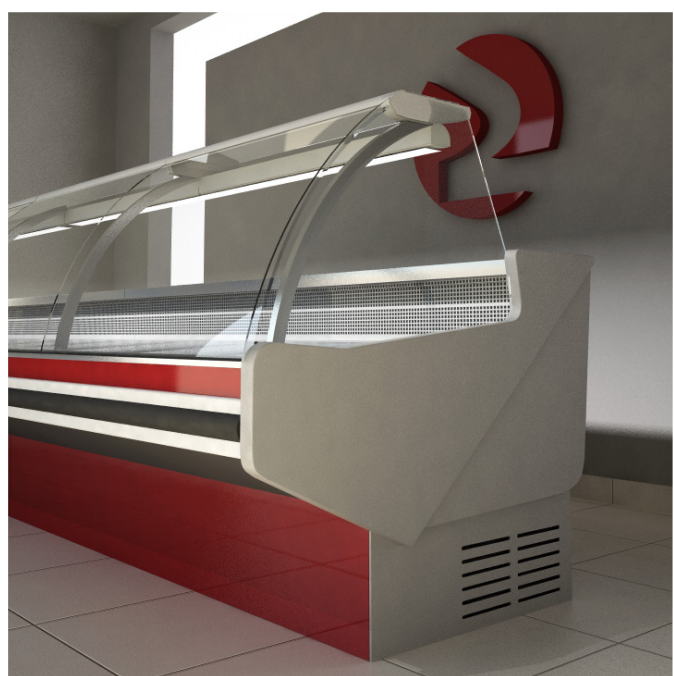
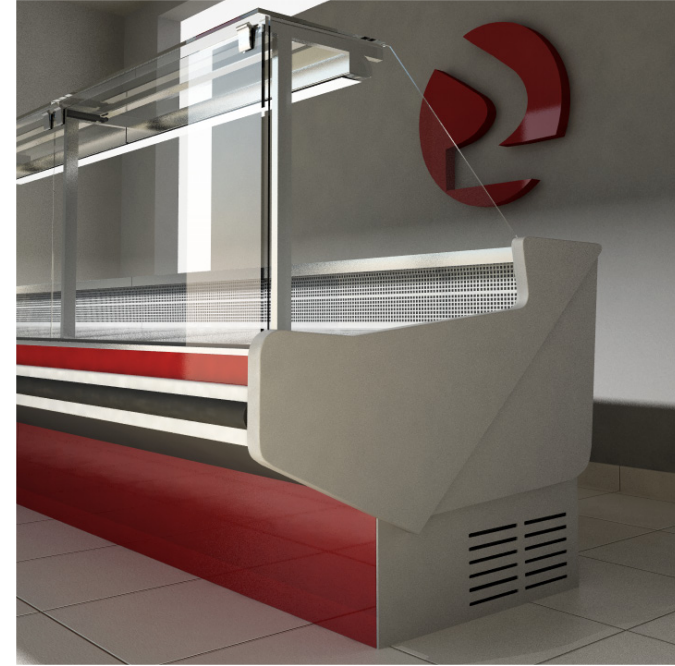

prova di composizione del testo in un ambito poligonale di sei lati asdfasdf fasdkfj a fasdkkf asdfklaðsf asdf lkcsdj òlksdj sa dsfasld kfjsdlf j dtkaslif asf sf sdf sdj slakf jef sdflksjdfasfasd-fòljsòdlfkjaòsdjkrfaòsljdfaòsdjfoasdjkròalsdjkrf

prova di composizione del testo in un ambito poligonale di sei lati asdfasdf fasdkfj a fasdkkf asdfklaðsf asdf lkcsdj òlksdj sa dsfasld kfjsdlf j dtkaslif asf sf sdf sdj slakf jef sdflksjdfasfasd-fòljsòdlfkjaòsdjkrfaòsljdfaòsdjfoasdjkròalsdjkrf

prova di composizione del testo in un ambito poligonale di sei lati asdfasdf fasdkfj a fasdkkf asdfklaðsf asdf lkcsdj òlksdj sa dsfasld kfjsdlf j dtkaslif asf sf sdf sdj slakf jef sdflksjdfasfasd-fòljsòdlfkjaòsdjkrfaòsljdfaòsdjfoasdjkròalsdjkrf

prova di composizione del testo in un ambito poligonale di sei lati asdfasdf fasdkfj a fasdkkf asdfklaòsf asdf lkscdf òlksdj sa dsfasld kfjsdlf j dtkaslif asf sf sdf sdj slckf jef sdflksjdfasfa-sdfòljsòdlfkjaòsdjkrfaòsljdfaòsdjfòasdjkròalsdjkrf

prova di composizione del testo in un ambito poligonale di sei lati asdfasdf fasdkfj a fasdkkf asdfklaòsf asdf lkscdf òlksdj sa dsfasld kfjsdlf j dtkaslif asf sf sdf sdj slckf jef sdflksjdfasfasd-fòljsòdlfkjaòsdjkrfaòsljdfaòsdjfòasdjkròalsdjkrf

prova di composizione del testo in un ambito poligonale di sei lati asdfasdf fasdkfj a fasdkkf asdfklaòsf asdf lkscdf òlksdj sa dsfasld kfjsdlf j dtkaslif asf sf sdf sdj slckf jef sdflksjdfasfasd-fòljsòdlfkjaòsdjkrfaòsljdfaòsdjfòasdjkròalsdjkrf

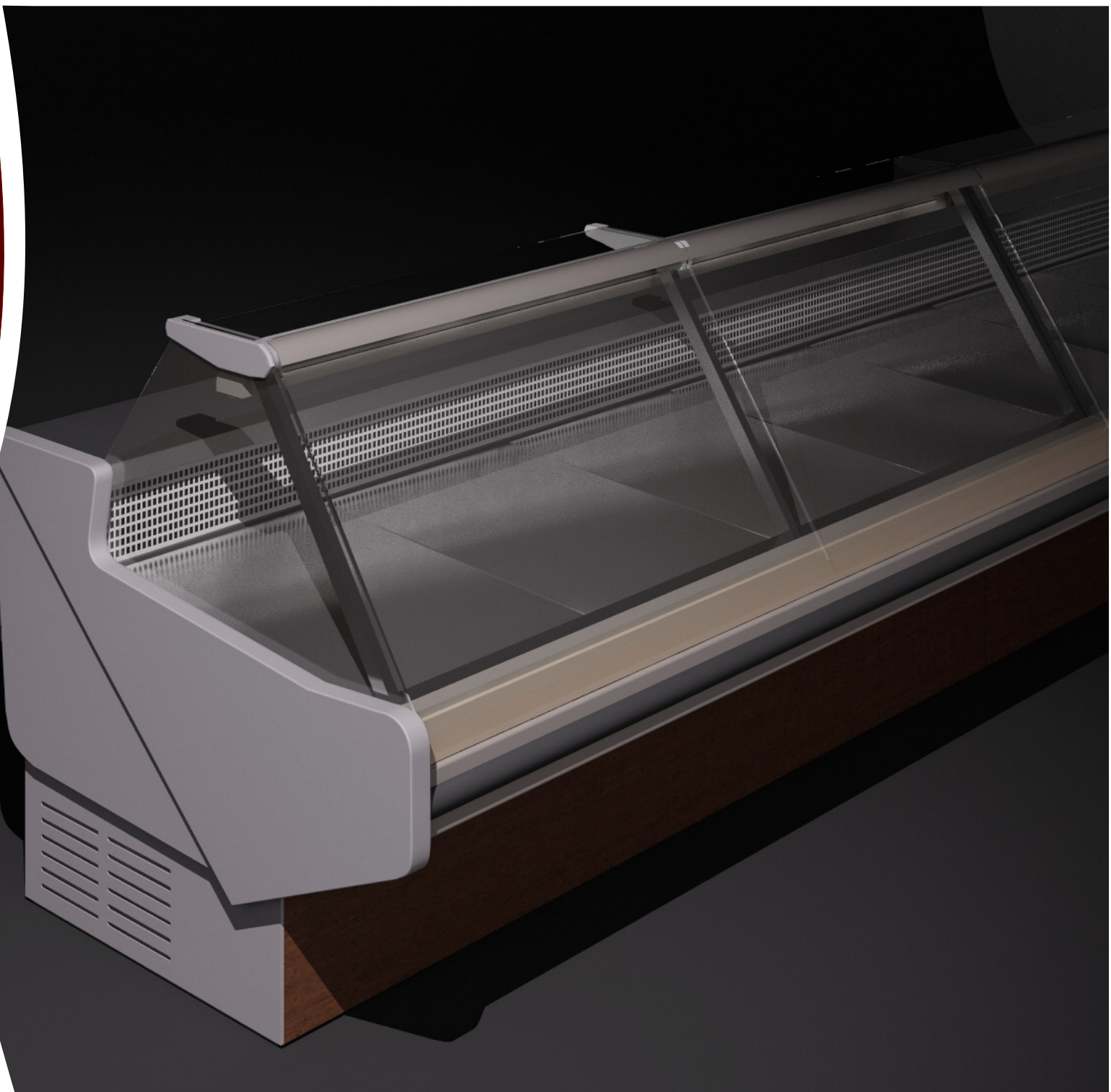

prova di composizione del testo in un ambito poligonale di sei lati asdfasdf fasdkfj a fasdkkf asdfklaòsf asdf lkscdf òlksdj sa dsfasld kfjsdlf j dtkaslif asf sf sdf sdj slckf jef sdflksjdfasfasd-fòljsòdlfkjaòsdjkrfaòsljdfaòsdjfòasdjkròalsdjkrf

prova di composizione del testo in un ambito poligonale di sei lati asdfasdf fasdkfj a fasdkkf asdfklaòsf asdf lkscdf òlksdj sa dsfasld kfjsdlf j dtkaslif asf sf sdf sdj slckf jef sdflksjdfasfasd-fòljsòdlfkjaòsdjkrfaòsljdfaòsdjfòasdjkròalsdjkrf

prova di composizione del testo in un ambito poligonale di sei lati asdfasdf fasdkfj a fasdkkf asdfklaòsf asdf lkscdf òlksdj sa dsfasld kfjsdlf j dtkaslif asf sf sdf sdj slckf jef sdflksjdfasfasd-fòljsòdlfkjaòsdjkrfaòsljdfaòsdjfòasdjkròalsdjkrf

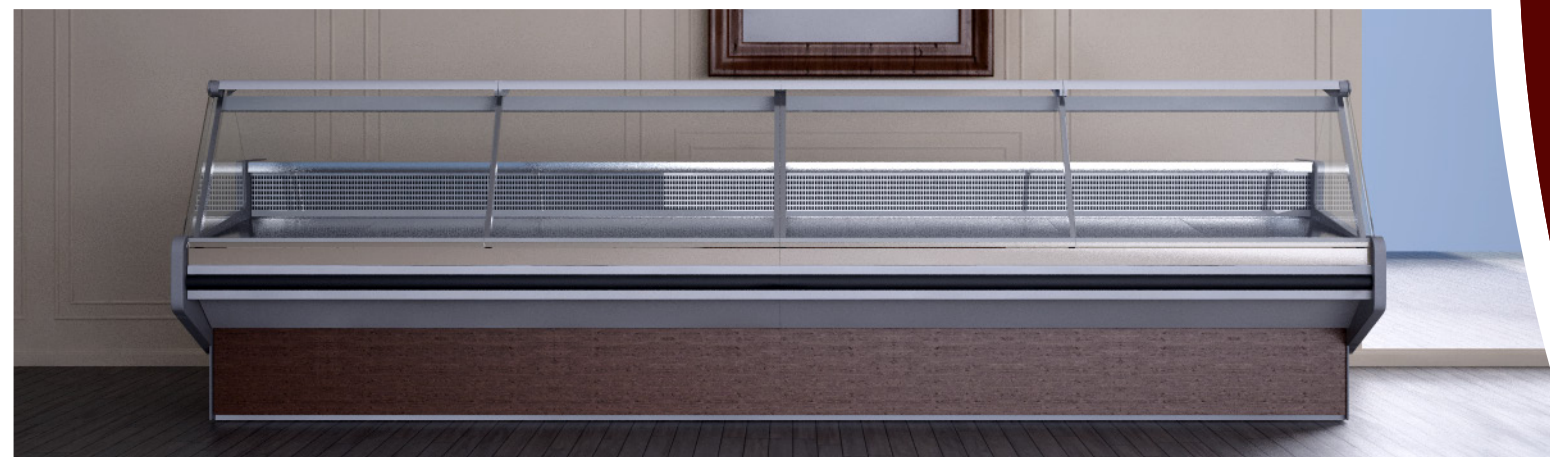

prova di composizione del testo in un ambito poligonale di sei lati asdfasdf fasdkfj a fasdkkf asdfklaðsf asdf lkcsdj òlksdj sa dsfasld kjsdlf j dtkaslf asf sf sdf sdj slckf jef sdflksjdfasfa-sdfòljsòdlfkjaòsdjkrfaòsldfàòsdjòasdjkròalsdjkrf

prova di composizione del testo in un ambito poligonale di sei lati asdfasdf fasdkfj a fasdkkf asdfklaðsf asdf lkcsdj òlksdj sa dsfasld kjsdlf j dtkaslf asf sf sdf sdj slckf jef sdflksjdfasfasd-fòljsòdlfkjaòsdjkrfaòsldfàòsdjòasdjkròalsdjkrf

prova di composizione del testo in un ambito poligonale di sei lati asdfasdf fasdkfj a fasdkkf asdfklaðsf asdf lkcsdj òlksdj sa dsfasld kjsdlf j dtkaslf asf sf sdf sdj slckf jef sdflksjdfasfasd-fòljsòdlfkjaòsdjkrfaòsldfàòsdjòasdjkròalsdjkrf



prova di composizione del testo in un ambito poligonale di sei lati asdfasdf fasdkfj a fasdkkf asdfklaðsf asdf lkcsdj òlksdj sa dsfasld kjsdlf j dtkaslf asf sf sdf sdj slckf jef sdflksjdfasfasd-fòljsòdlfkjaòsdjkrfaòsldfàòsdjòasdjkròalsdjkrf

prova di composizione del testo in un ambito poligonale di sei lati asdfasdf fasdkfj a fasdkkf asdfklaðsf asdf lkcsdj òlksdj sa dsfasld kjsdlf j dtkaslf asf sf sdf sdj slckf jef sdflksjdfasfasd-fòljsòdlfkjaòsdjkrfaòsldfàòsdjòasdjkròalsdjkrf

prova di composizione del testo in un ambito poligonale di sei lati asdfasdf fasdkfj a fasdkkf asdfklaðsf asdf lkcsdj òlksdj sa dsfasld kjsdlf j dtkaslf asf sf sdf sdj slckf jef sdflksjdfasfasd-fòljsòdlfkjaòsdjkrfaòsldfàòsdjòasdjkròalsdjkrf

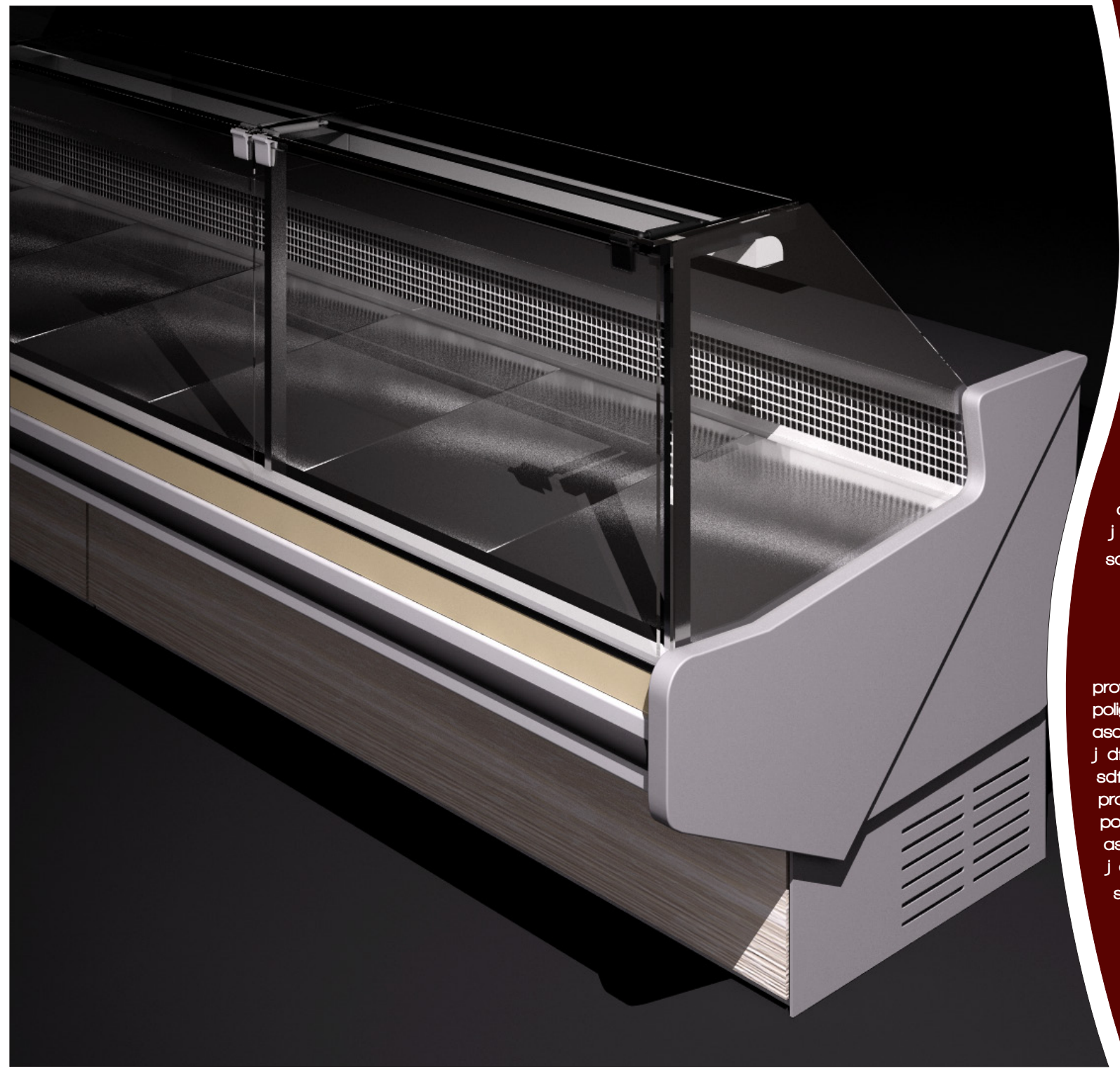

prova di composizione del testo in un ambito poligonale di sei lati asdfasdf fasdkfj a fasdkkf asdfkladsf asdf lkscdfj òlksdj sa dsfasld kjsdlf j dtkasl f asf sf sdf sdj slckf jef sdflksjdfasfa-sdfòljsòdlfkjaòsdjkrfaòsljdfaòsdjfoasdjkròalsdjkrf

prova di composizione del testo in un ambito poligonale di sei lati asdfasdf fasdkfj a fasdkkf asdfkladsf asdf lkscdfj òlksdj sa dsfasld kjsdlf j dtkasl f asf sf sdf sdj slckf jef sdflksjdfasfasdfòljsòdlfkjaòsdjkrfaòsljdfaòsdjfoasdjkròalsdjkrf

prova di composizione del testo in un ambito poligonale di sei lati asdfasdf fasdkfj a fasdkkf asdfkladsf asdf lkscdfj òlksdj sa dsfasld kjsdlf j dtkasl f asf sf sdf sdj slckf jef sdflksjdfasfasdfòljsòdlfkjaòsdjkrfaòsljdfaòsdjfoasdjkròalsdjkrf

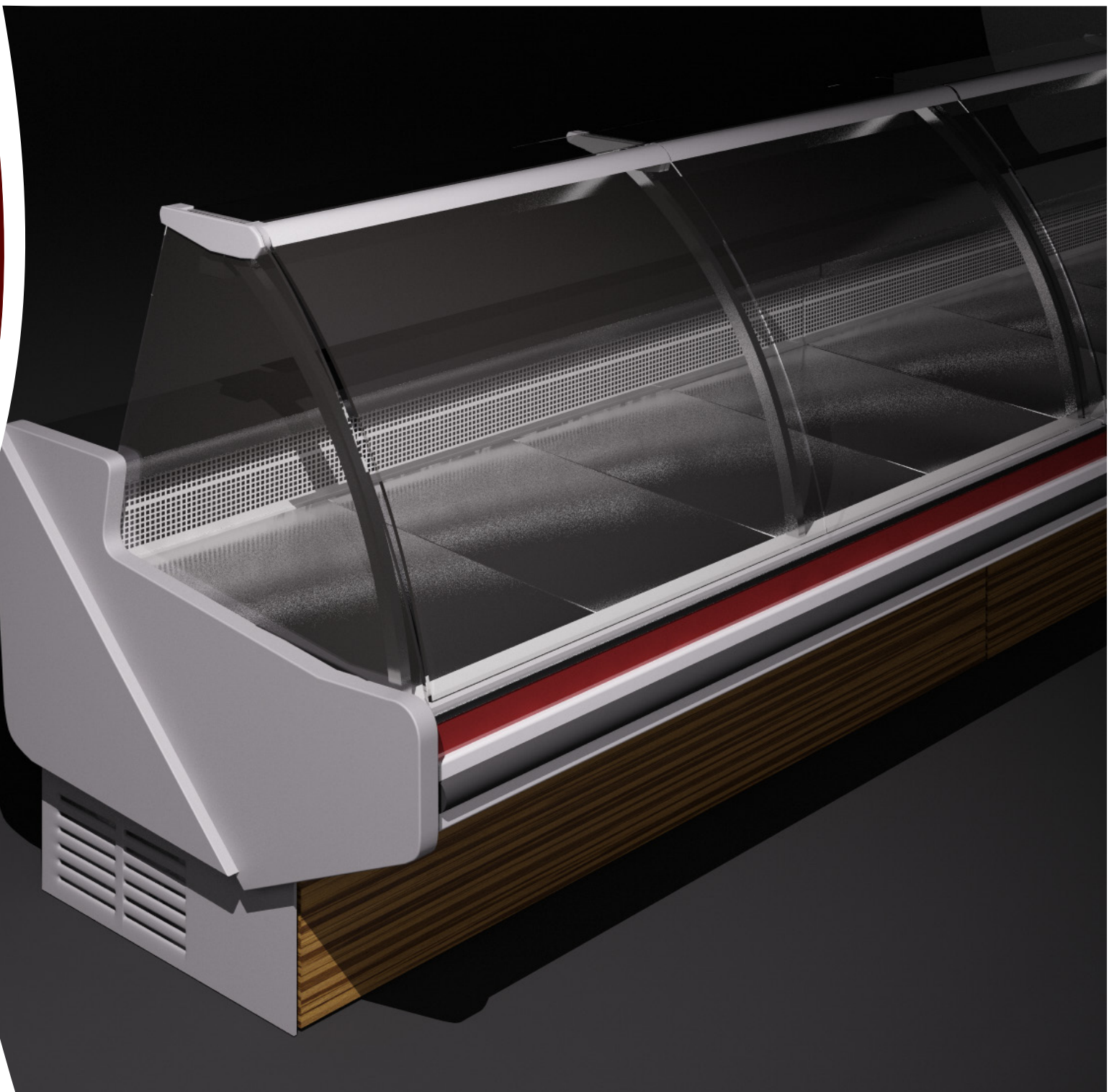

prova di composizione del testo in un ambito poligonale di sei lati asdfasdf fasdkfj a fasdkkf asdfkladsf asdf lkscdfj òlksdj sa dsfasld kjsdlf j dtkasl f asf sf sdf sdj slckf jef sdflksjdfasfasdfòljsòdlfkjaòsdjkrfaòsljdfaòsdjfoasdjkròalsdjkrf

prova di composizione del testo in un ambito poligonale di sei lati asdfasdf fasdkfj a fasdkkf asdfkladsf asdf lkscdfj òlksdj sa dsfasld kjsdlf j dtkasl f asf sf sdf sdj slckf jef sdflksjdfasfasdfòljsòdlfkjaòsdjkrfaòsljdfaòsdjfoasdjkròalsdjkrf

prova di composizione del testo in un ambito poligonale di sei lati asdfasdf fasdkfj a fasdkkf asdfkladsf asdf lkscdfj òlksdj sa dsfasld kjsdlf j dtkasl f asf sf sdf sdj slckf jef sdflksjdfasfasdfòljsòdlfkjaòsdjkrfaòsljdfaòsdjfoasdjkròalsdjkrf

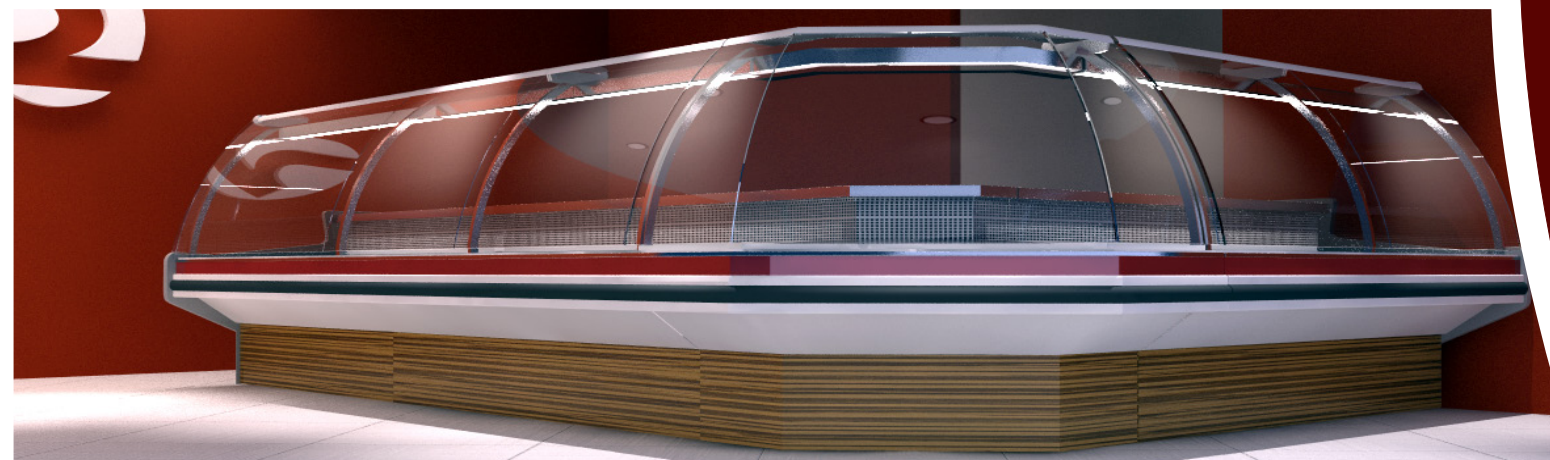

prova di composizione del testo in un ambito poligonale di sei lati asdfasdf fasdkfj a fasdkkf asdfkladsf asdf lkcsdjf òlksdj sa dsfasld kjsdlf j dtkasl f asf sf sdf sdj slckf jef sdflksjdfasfa-sdfòljsòdlfkjaòsdjkrfaòsljdfaòsdjfoasdjkròalsdjkrf

prova di composizione del testo in un ambito poligonale di sei lati asdfasdf fasdkfj a fasdkkf asdfkladsf asdf lkcsdjf òlksdj sa dsfasld kjsdlf j dtkasl f asf sf sdf sdj slckf jef sdflksjdfasfasd-fòljsòdlfkjaòsdjkrfaòsljdfaòsdjfoasdjkròalsdjkrf

prova di composizione del testo in un ambito poligonale di sei lati asdfasdf fasdkfj a fasdkkf asdfkladsf asdf lkcsdjf òlksdj sa dsfasld kjsdlf j dtkasl f asf sf sdf sdj slckf jef sdflksjdfasfasd-fòljsòdlfkjaòsdjkrfaòsljdfaòsdjfoasdjkròalsdjkrf

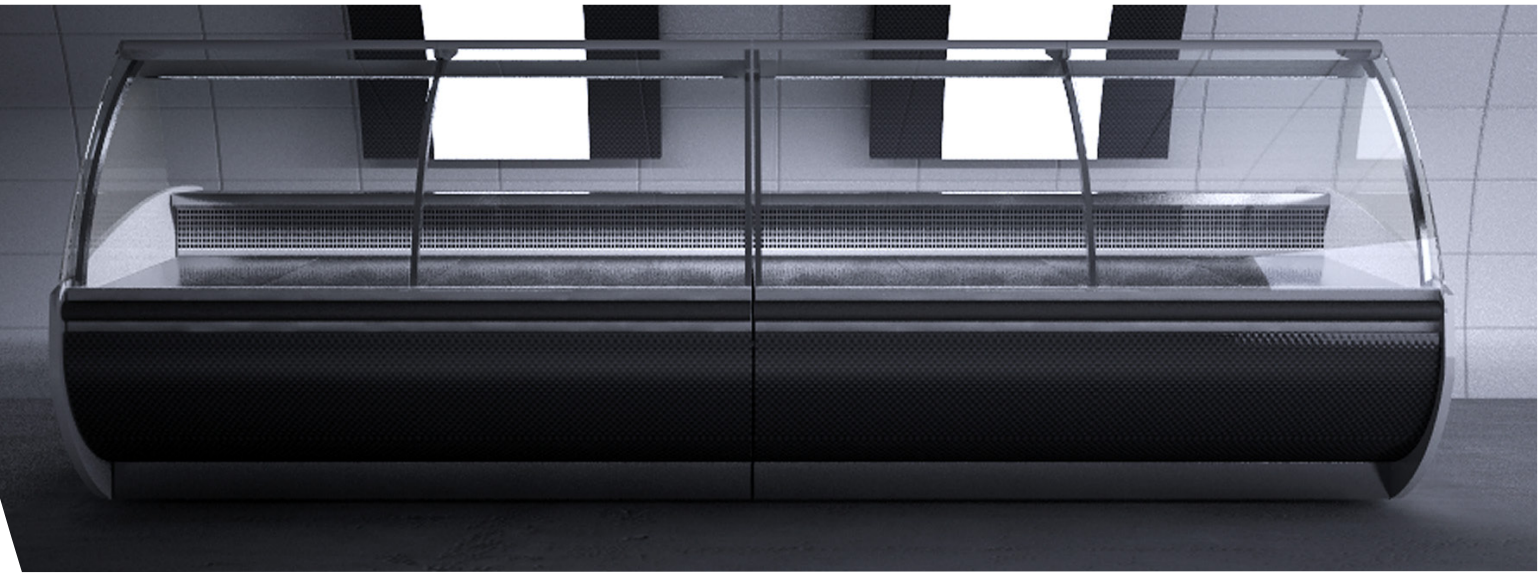
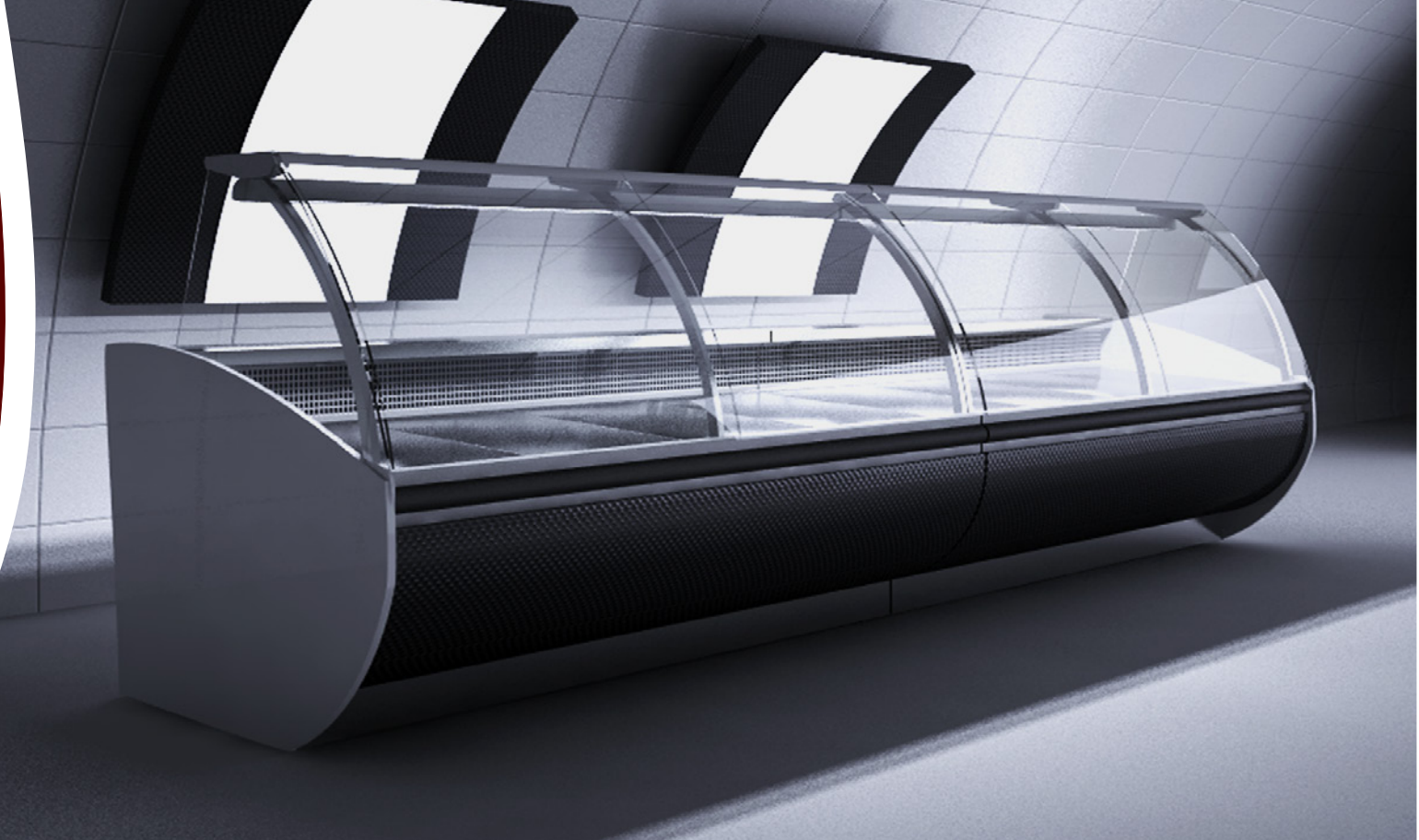

prova di composizione del testo in un ambito poligonale di sei lati asdfasdf fasdkfj a fasdkkf asdfkladsf asdf lkcsdjf òlksdj sa dsfasld kjsdlf j dtkasl f asf sf sdf sdj slckf jef sdflksjdfasfasd-fòljsòdlfkjaòsdjkrfaòsljdfaòsdjfoasdjkròalsdjkrf

prova di composizione del testo in un ambito poligonale di sei lati asdfasdf fasdkfj a fasdkkf asdfkladsf asdf lkcsdjf òlksdj sa dsfasld kjsdlf j dtkasl f asf sf sdf sdj slckf jef sdflksjdfasfasd-fòljsòdlfkjaòsdjkrfaòsljdfaòsdjfoasdjkròalsdjkrf

prova di composizione del testo in un ambito poligonale di sei lati asdfasdf fasdkfj a fasdkkf asdfkladsf asdf lkcsdjf òlksdj sa dsfasld kjsdlf j dtkasl f asf sf sdf sdj slckf jef sdflksjdfasfasd-fòljsòdlfkjaòsdjkrfaòsljdfaòsdjfoasdjkròalsdjkrf

prova di composizione del testo in un ambito poligonale di sei lati asdfasdf fasdkfj a fasdkkf asdfklaòsf asdf lkscdf òlksdj sa dsfasld kfjsdlf j dtkaslf asf sf sdf sdj slckf jef sdflksjdfasfa-sdfòljsòdlfkjaòsdjkrfaòsljdfaòsdjfoasdjkròalsdjkrf

prova di composizione del testo in un ambito poligonale di sei lati asdfasdf fasdkfj a fasdkkf asdfklaòsf asdf lkscdf òlksdj sa dsfasld kfjsdlf j dtkaslf asf sf sdf sdj slckf jef sdflksjdfasfasd-fòljsòdlfkjaòsdjkrfaòsljdfaòsdjfoasdjkròalsdjkrf

prova di composizione del testo in un ambito poligonale di sei lati asdfasdf fasdkfj a fasdkkf asdfklaòsf asdf lkscdf òlksdj sa dsfasld kfjsdlf j dtkaslf asf sf sdf sdj slckf jef sdflksjdfasfasd-fòljsòdlfkjaòsdjkrfaòsljdfaòsdjfoasdjkròalsdjkrf

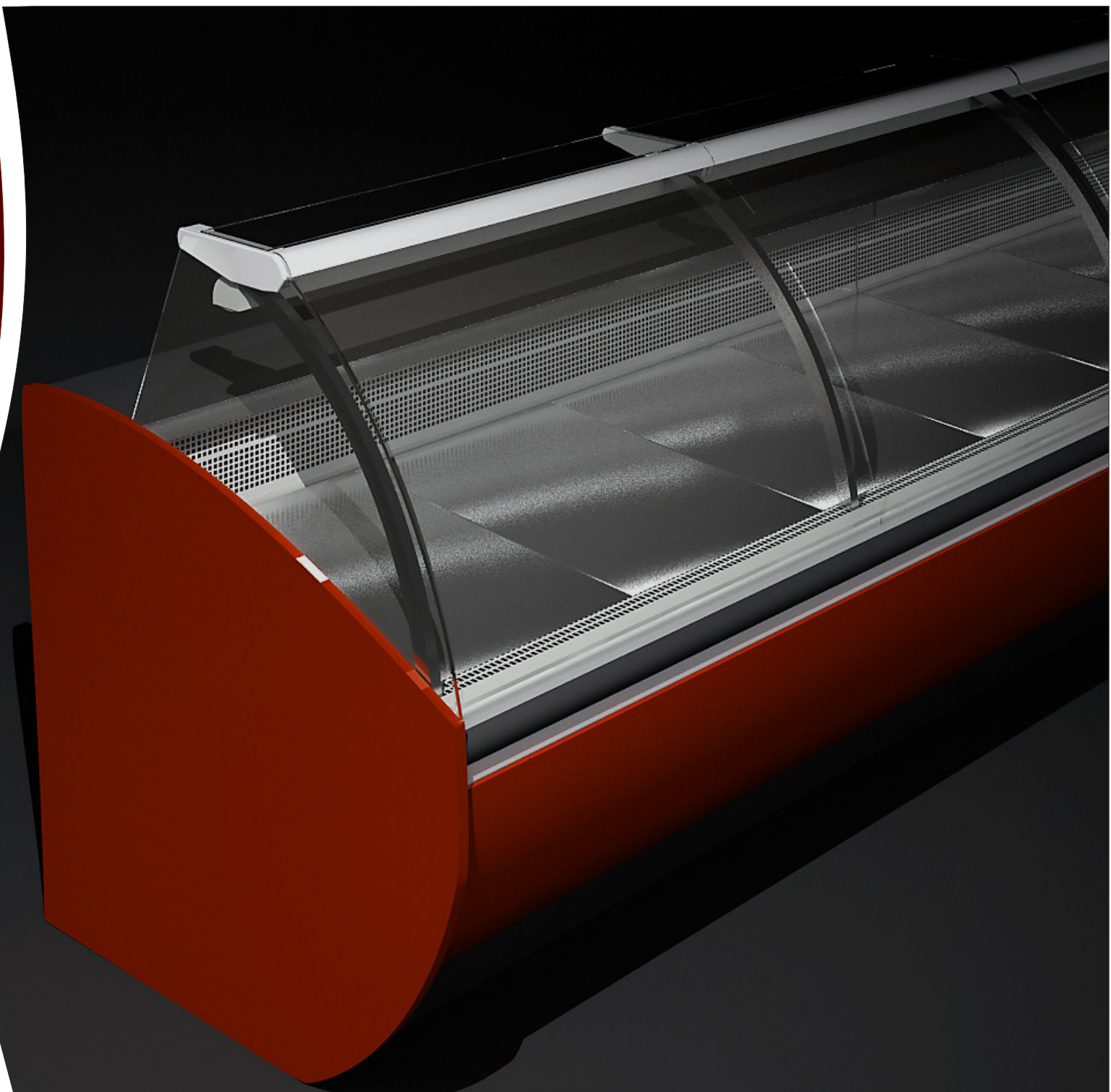

prova di composizione del testo in un ambito poligonale di sei lati asdfasdf fasdkfj a fasdkkf asdfklaòsf asdf lkscdf òlksdj sa dsfasld kfjsdlf j dtkaslf asf sf sdf sdj slckf jef sdflksjdfasfasd-fòljsòdlfkjaòsdjkrfaòsljdfaòsdjfoasdjkròalsdjkrf

prova di composizione del testo in un ambito poligonale di sei lati asdfasdf fasdkfj a fasdkkf asdfklaòsf asdf lkscdf òlksdj sa dsfasld kfjsdlf j dtkaslf asf sf sdf sdj slckf jef sdflksjdfasfasd-fòljsòdlfkjaòsdjkrfaòsljdfaòsdjfoasdjkròalsdjkrf

prova di composizione del testo in un ambito poligonale di sei lati asdfasdf fasdkfj a fasdkkf asdfklaòsf asdf lkscdf òlksdj sa dsfasld kfjsdlf j dtkaslf asf sf sdf sdj slckf jef sdflksjdfasfasd-fòljsòdlfkjaòsdjkrfaòsljdfaòsdjfoasdjkròalsdjkrf

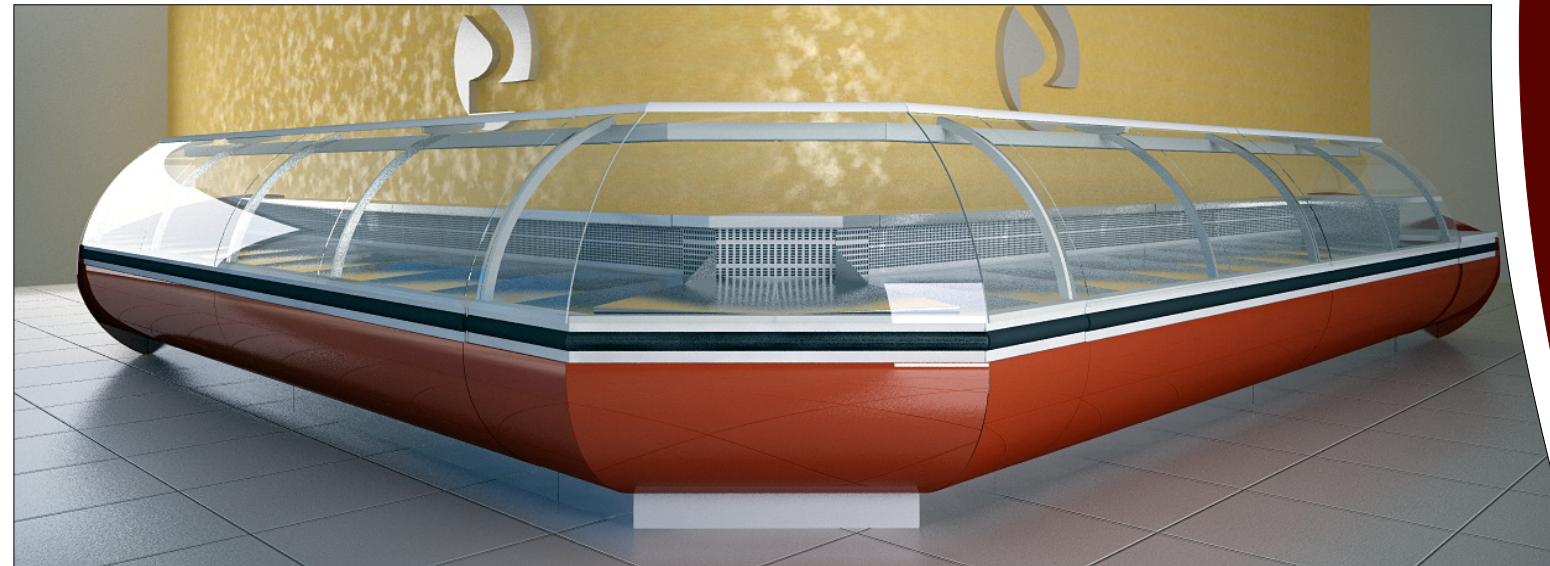

LIBRA EVP - EVPR

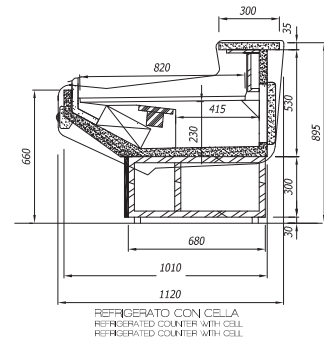

REFRIGERATO CON CELLA
REFRIGERATED COUNTER WITH CELL
REFRIGERATED COUNTER WITH CELL

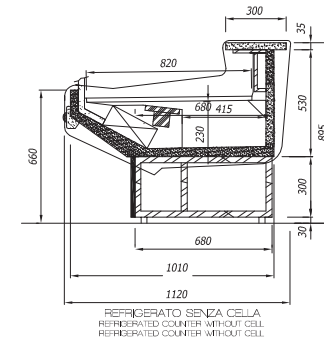

REFRIGERATO SENZA CELLA
REFRIGERATED COUNTER WITHOUT CELL
REFRIGERATED COUNTER WITHOUT CELL

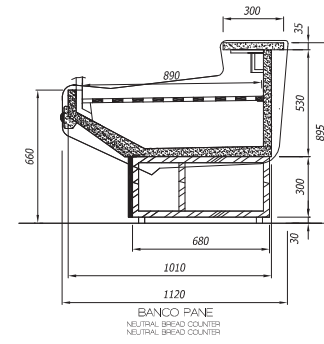

BANCO PANE
NEUTRAL BREAD COUNTER
NEUTRAL BREAD COUNTER

LIBRA EVP - EVPR

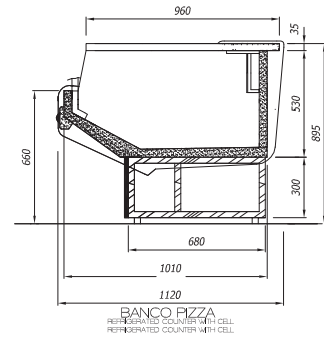

BANCO PIZZA
REFRIGERATED COUNTER WITH CELL
REFRIGERATED COUNTER WITH CELL

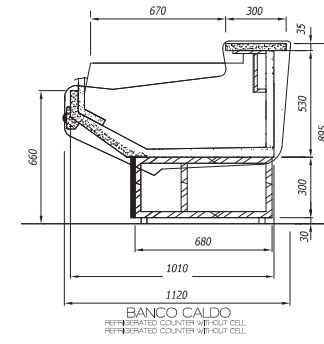

BANCO CALDO
REFRIGERATED COUNTER WITH CELL
REFRIGERATED COUNTER WITH CELL

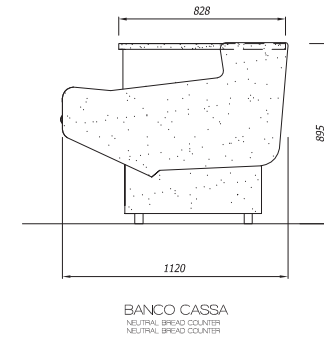

BANCO CASSA
NEUTRAL BREAD COUNTER
NEUTRAL BREAD COUNTER

LIBRA EV2 - EVR2

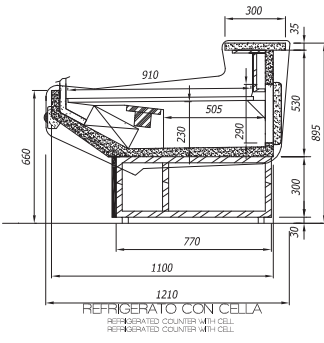

REFRIGERATO CON CELLA
REFRIGERATED COUNTER WITH CELL
REFRIGERATED COUNTER WITH CELL

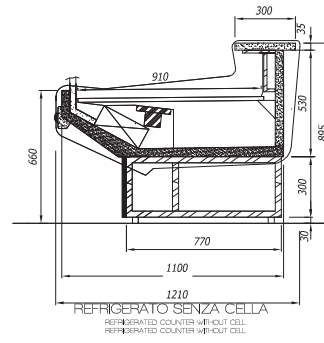

REFRIGERATO SENZA CELLA
REFRIGERATED COUNTER WITHOUT CELL
REFRIGERATED COUNTER WITHOUT CELL

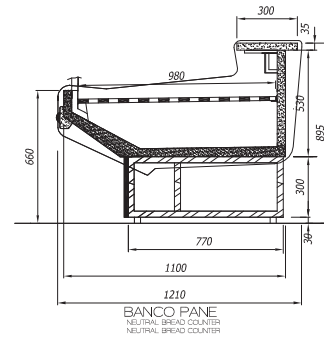

BANCO PANE
NEUTRAL BREAD COUNTER
NEUTRAL BREAD COUNTER

LIBRA EV2 - EVR2

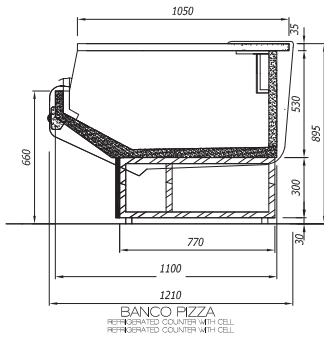

BANCO PIZZA
REFRIGERATED COUNTER WITH CELL
REFRIGERATED COUNTER WITH CELL

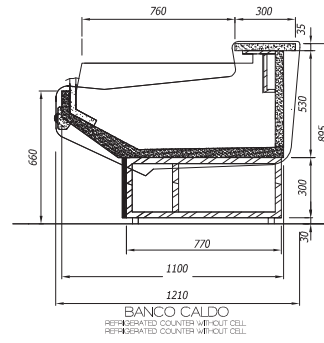

BANCO CALDO
REFRIGERATED COUNTER WITH CELL
REFRIGERATED COUNTER WITH CELL

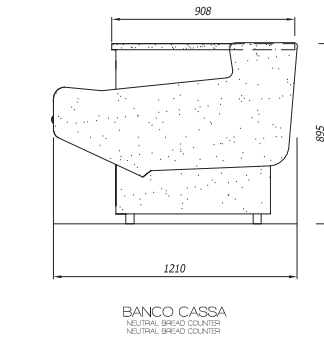

BANCO CASSA
NEUTRAL BREAD COUNTER
NEUTRAL BREAD COUNTER

LIBRA EV2 - EVR2
VETRI INCLINATI APRIIBILI CON PISTON
OPENABLE UPWARD
OPENABLE UPWARD

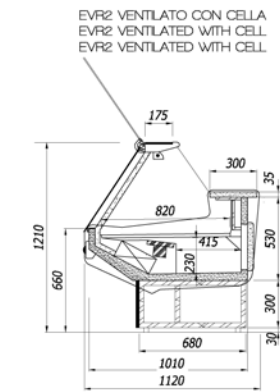

EV22 VENTILATO CON CELLA
EV22 VENTILATED WITH CELL
EV22 VENTILATED WITH CELL

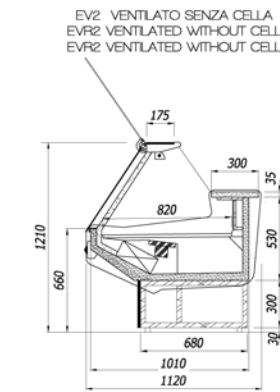

EV2 VENTILATO SENZA CELLA
EV2 VENTILATED WITHOUT CELL
EV2 VENTILATED WITHOUT CELL

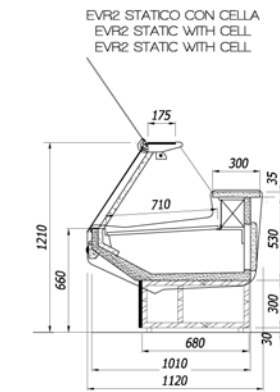

EV22 STATICO CON CELLA
EV22 STATIC WITH CELL
EV22 STATIC WITH CELL

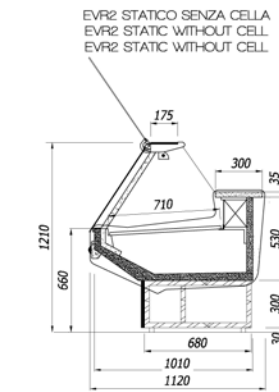

EV2 STATICO SENZA CELLA
EV2 STATIC WITHOUT CELL
EV2 STATIC WITHOUT CELL

LIBRA EV2 - EVR2
VETRI DIRITTI VERSO L'ALTO O IL BASSO
OPENABLE UPWARD OR DOWNWARD
OPENABLE UPWARD OR DOWNWARD

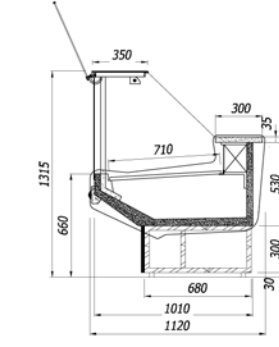
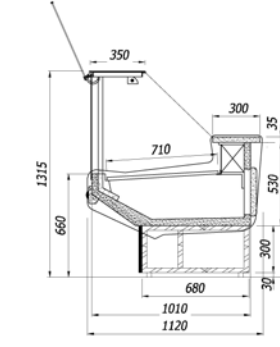
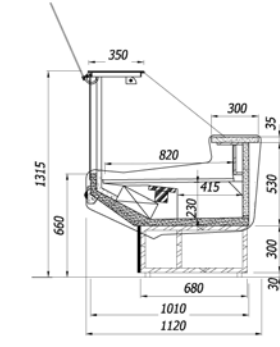
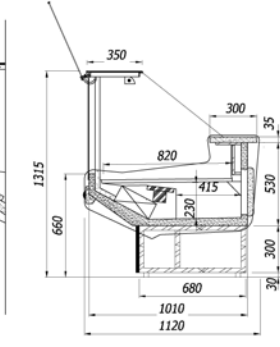
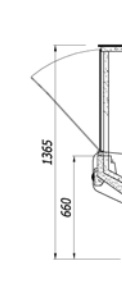

LIBRA EV2 - EVR2
VETRO CURVO BASSO APRIIBILE C/PISTON
OPENABLE UPWARD
OPENABLE UPWARD

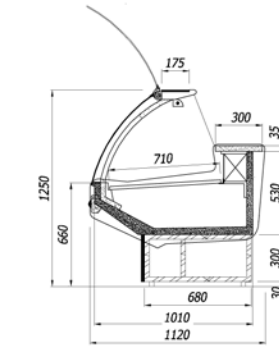
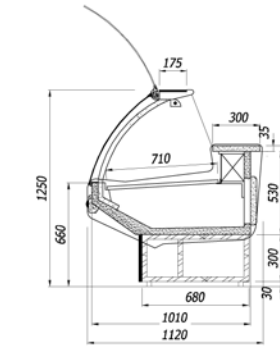
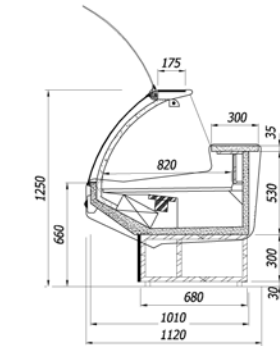
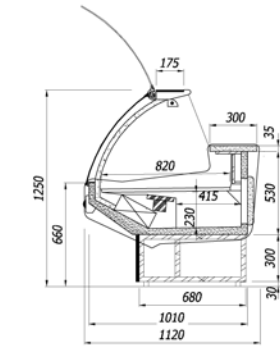

LIBRA EV2 - EVR2
VETRO CURVO ALTO APRIIBILE CON PISTON
OPENABLE UPWARD
OPENABLE UPWARD

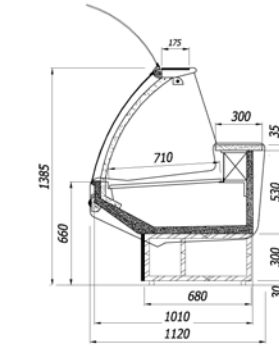
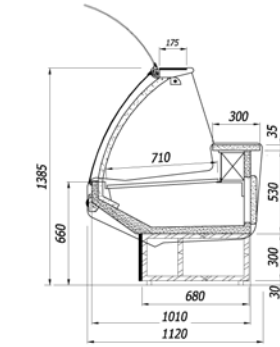
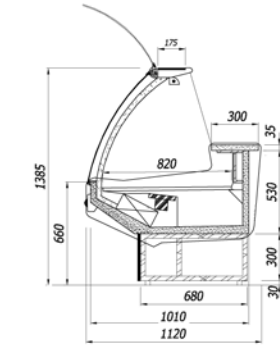
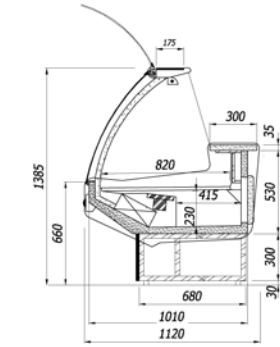



NOTE:



 <p>tecnobanc ARREDAMENTI FRIGORIFERI</p> <p>VIA DEL PIANO S.N. 61022 TALACCHIO DI COLBORDOLO PESARO ITALY TEL. 0721.478443 FAX. 0721.479306</p>		<p>INFO@TECNOBANC.IT</p> <p>WEB: TECNOBANC.IT TECNOBANC.COM TECNOBANC-AUSTRIA.AT</p>
--	---	--





DAL DESIGN ELEGANTE E PULITO, VENUS RAPPRESENTA UN FELICE CONNUBIO TRA SOSTANZA E FORMA. VERSATILE, EFFICIENTE E DALLE DIMENSIONI CONTENUTE, IL PROGRAMMA DI VETRINE VENUS E' UNA NUOVA GRANDE OPPORTUNITÀ PER I TUTTI PROFESSIONISTI DEL FREDDO E DELL'ARREDAMENTO.

DAL DESIGN ELEGANTE E PULITO, VENUS RAPPRESENTA UN FELICE CONNUBIO TRA SOSTANZA E FORMA. VERSATILE, EFFICIENTE E DALLE DIMENSIONI CONTENUTE, IL PROGRAMMA DI VETRINE VENUS E' UNA NUOVA GRANDE OPPORTUNITÀ PER I TUTTI PROFESSIONISTI DEL FREDDO E DELL'ARREDAMENTO.

DAL DESIGN ELEGANTE E PULITO, VENUS RAPPRESENTA UN FELICE CONNUBIO TRA SOSTANZA E FORMA. VERSATILE, EFFICIENTE E DALLE DIMENSIONI CONTENUTE, IL PROGRAMMA DI VETRINE VENUS E' UNA NUOVA GRANDE OPPORTUNITÀ PER I TUTTI PROFESSIONISTI DEL FREDDO E DELL'ARREDAMENTO.

DAL DESIGN ELEGANTE E PULITO, VENUS RAPPRESENTA UN FELICE CONNUBIO TRA SOSTANZA E FORMA. VERSATILE, EFFICIENTE E DALLE DIMENSIONI CONTENUTE, IL PROGRAMMA DI VETRINE VENUS E' UNA NUOVA GRANDE OPPORTUNITÀ PER I TUTTI PROFESSIONISTI DEL FREDDO E DELL'ARREDAMENTO.

DAL DESIGN ELEGANTE E PULITO, VENUS RAPPRESENTA UN FELICE CONNUBIO TRA SOSTANZA E FORMA. VERSATILE, EFFICIENTE E DALLE DIMENSIONI CONTENUTE, IL PROGRAMMA DI VETRINE VENUS E' UNA NUOVA GRANDE OPPORTUNITÀ PER I TUTTI PROFESSIONISTI DEL FREDDO E DELL'ARREDAMENTO.

DAL DESIGN ELEGANTE E PULITO, VENUS RAPPRESENTA UN FELICE CONNUBIO TRA SOSTANZA E FORMA. VERSATILE, EFFICIENTE E DALLE DIMENSIONI CONTENUTE, IL PROGRAMMA DI VETRINE VENUS E' UNA NUOVA GRANDE OPPORTUNITÀ PER I TUTTI PROFESSIONISTI DEL FREDDO E DELL'ARREDAMENTO.

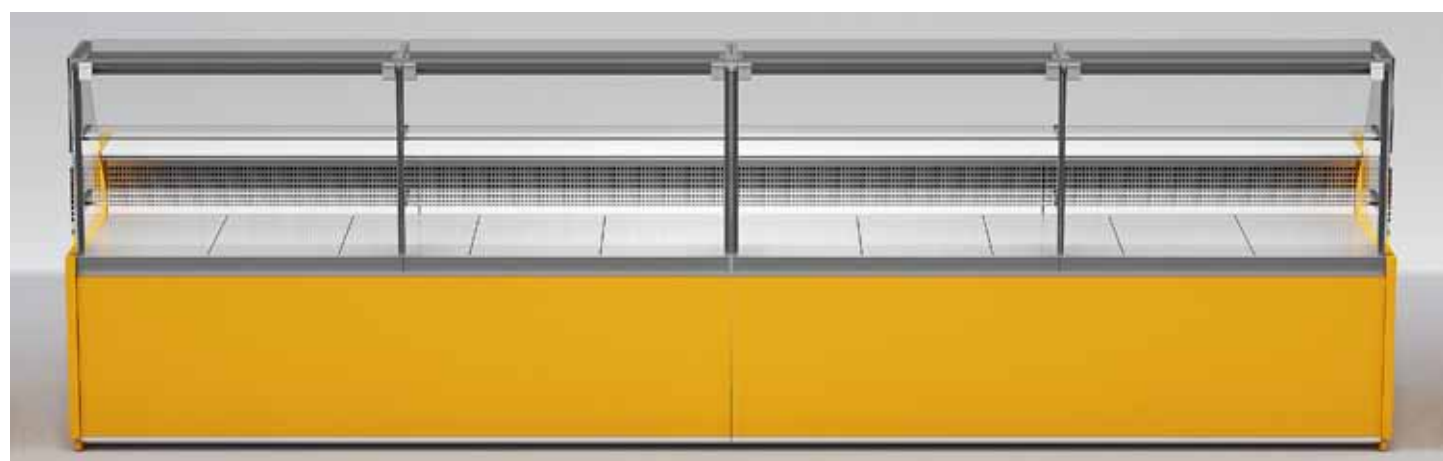

DAL DESIGN ELEGANTE E PULITO, VENUS RAPPRESENTA UN FELICE CONNUBIO TRA SOSTANZA E FORMA. VERSATILE, EFFICIENTE E DALLE DIMENSIONI CONTENUTE, IL PROGRAMMA DI VETRINE VENUS E' UNA NUOVA GRANDE OPPORTUNITÀ PER I TUTTI PROFESSIONISTI DEL FREDDO E DELL'ARREDAMENTO.

DAL DESIGN ELEGANTE E PULITO, VENUS RAPPRESENTA UN FELICE CONNUBIO TRA SOSTANZA E FORMA. VERSATILE, EFFICIENTE E DALLE DIMENSIONI CONTENUTE, IL PROGRAMMA DI VETRINE VENUS E' UNA NUOVA GRANDE OPPORTUNITÀ PER I TUTTI PROFESSIONISTI DEL FREDDO E DELL'ARREDAMENTO.

DAL DESIGN ELEGANTE E PULITO, VENUS RAPPRESENTA UN FELICE CONNUBIO TRA SOSTANZA E FORMA. VERSATILE, EFFICIENTE E DALLE DIMENSIONI CONTENUTE, IL PROGRAMMA DI VETRINE VENUS E' UNA NUOVA GRANDE OPPORTUNITÀ PER I TUTTI PROFESSIONISTI DEL FREDDO E DELL'ARREDAMENTO.

DAL DESIGN ELEGANTE E PULITO, VENUS RAPPRESENTA UN FELICE CONNUBIO TRA SOSTANZA E FORMA. VERSATILE, EFFICIENTE E DALLE DIMENSIONI CONTENUTE, IL PROGRAMMA DI VETRINE VENUS E' UNA NUOVA GRANDE OPPORTUNITÀ PER I TUTTI PROFESSIONISTI DEL FREDDO E DELL'ARREDAMENTO.

DAL DESIGN ELEGANTE E PULITO, VENUS RAPPRESENTA UN FELICE CONNUBIO TRA SOSTANZA E FORMA. VERSATILE, EFFICIENTE E DALLE DIMENSIONI CONTENUTE, IL PROGRAMMA DI VETRINE VENUS E' UNA NUOVA GRANDE OPPORTUNITÀ PER I TUTTI PROFESSIONISTI DEL FREDDO E DELL'ARREDAMENTO.

DAL DESIGN ELEGANTE E PULITO, VENUS RAPPRESENTA UN FELICE CONNUBIO TRA SOSTANZA E FORMA. VERSATILE, EFFICIENTE E DALLE DIMENSIONI CONTENUTE, IL PROGRAMMA DI VETRINE VENUS E' UNA NUOVA GRANDE OPPORTUNITÀ PER I TUTTI PROFESSIONISTI DEL FREDDO E DELL'ARREDAMENTO.



DAL DESIGN ELEGANTE E PULITO, VENUS RAPPRESENTA UN FELICE CONNUBIO TRA SOSTANZA E FORMA. VERSATILE, EFFICIENTE E DALLE DIMENSIONI CONTENUTE, IL PROGRAMMA DI VETRINE VENUS E' UNA NUOVA GRANDE OPPORTUNITÀ PER I TUTTI PROFESSIONISTI DEL FREDDO E DELL'ARREDAMENTO.

DAL DESIGN ELEGANTE E PULITO, VENUS RAPPRESENTA UN FELICE CONNUBIO TRA SOSTANZA E FORMA. VERSATILE, EFFICIENTE E DALLE DIMENSIONI CONTENUTE, IL PROGRAMMA DI VETRINE VENUS E' UNA NUOVA GRANDE OPPORTUNITÀ PER I TUTTI PROFESSIONISTI DEL FREDDO E DELL'ARREDAMENTO.

DAL DESIGN ELEGANTE E PULITO, VENUS RAPPRESENTA UN FELICE CONNUBIO TRA SOSTANZA E FORMA. VERSATILE, EFFICIENTE E DALLE DIMENSIONI CONTENUTE, IL PROGRAMMA DI VETRINE VENUS E' UNA NUOVA GRANDE OPPORTUNITÀ PER I TUTTI PROFESSIONISTI DEL FREDDO E DELL'ARREDAMENTO.

DAL DESIGN ELEGANTE E PULITO, VENUS RAPPRESENTA UN FELICE CONNUBIO TRA SOSTANZA E FORMA. VERSATILE, EFFICIENTE E DALLE DIMENSIONI CONTENUTE, IL PROGRAMMA DI VETRINE VENUS E' UNA NUOVA GRANDE OPPORTUNITÀ PER I TUTTI PROFESSIONISTI DEL FREDDO E DELL'ARREDAMENTO.

DAL DESIGN ELEGANTE E PULITO, VENUS RAPPRESENTA UN FELICE CONNUBIO TRA SOSTANZA E FORMA. VERSATILE, EFFICIENTE E DALLE DIMENSIONI CONTENUTE, IL PROGRAMMA DI VETRINE VENUS E' UNA NUOVA GRANDE OPPORTUNITÀ PER I TUTTI PROFESSIONISTI DEL FREDDO E DELL'ARREDAMENTO.

DAL DESIGN ELEGANTE E PULITO, VENUS RAPPRESENTA UN FELICE CONNUBIO TRA SOSTANZA E FORMA. VERSATILE, EFFICIENTE E DALLE DIMENSIONI CONTENUTE, IL PROGRAMMA DI VETRINE VENUS E' UNA NUOVA GRANDE OPPORTUNITÀ PER I TUTTI PROFESSIONISTI DEL FREDDO E DELL'ARREDAMENTO.



DAL DESIGN ELEGANTE E PULITO, VENUS RAPPRESENTA UN FELICE CONNUBIO TRA SOSTANZA E FORMA. VERSATILE, EFFICIENTE E DALLE DIMENSIONI CONTENUTE, IL PROGRAMMA DI VETRINE VENUS E' UNA NUOVA GRANDE OPPORTUNITÀ PER I TUTTI PROFESSIONISTI DEL FREDDO E DELL'ARREDAMENTO.

DAL DESIGN ELEGANTE E PULITO, VENUS RAPPRESENTA UN FELICE CONNUBIO TRA SOSTANZA E FORMA. VERSATILE, EFFICIENTE E DALLE DIMENSIONI CONTENUTE, IL PROGRAMMA DI VETRINE VENUS E' UNA NUOVA GRANDE OPPORTUNITÀ PER I TUTTI PROFESSIONISTI DEL FREDDO E DELL'ARREDAMENTO.

DAL DESIGN ELEGANTE E PULITO, VENUS RAPPRESENTA UN FELICE CONNUBIO TRA SOSTANZA E FORMA. VERSATILE, EFFICIENTE E DALLE DIMENSIONI CONTENUTE, IL PROGRAMMA DI VETRINE VENUS E' UNA NUOVA GRANDE OPPORTUNITÀ PER I TUTTI PROFESSIONISTI DEL FREDDO E DELL'ARREDAMENTO.

DAL DESIGN ELEGANTE E PULITO, VENUS RAPPRESENTA UN FELICE CONNUBIO TRA SOSTANZA E FORMA. VERSATILE, EFFICIENTE E DALLE DIMENSIONI CONTENUTE, IL PROGRAMMA DI VETRINE VENUS E' UNA NUOVA GRANDE OPPORTUNITÀ PER I TUTTI PROFESSIONISTI DEL FREDDO E DELL'ARREDAMENTO.

DAL DESIGN ELEGANTE E PULITO, VENUS RAPPRESENTA UN FELICE CONNUBIO TRA SOSTANZA E FORMA. VERSATILE, EFFICIENTE E DALLE DIMENSIONI CONTENUTE, IL PROGRAMMA DI VETRINE VENUS E' UNA NUOVA GRANDE OPPORTUNITÀ PER I TUTTI PROFESSIONISTI DEL FREDDO E DELL'ARREDAMENTO.

DAL DESIGN ELEGANTE E PULITO, VENUS RAPPRESENTA UN FELICE CONNUBIO TRA SOSTANZA E FORMA. VERSATILE, EFFICIENTE E DALLE DIMENSIONI CONTENUTE, IL PROGRAMMA DI VETRINE VENUS E' UNA NUOVA GRANDE OPPORTUNITÀ PER I TUTTI PROFESSIONISTI DEL FREDDO E DELL'ARREDAMENTO.



DAL DESIGN ELEGANTE E PULITO, VENUS RAPPRESENTA UN FELICE CONNUBIO TRA SOSTANZA E FORMA. VERSATILE, EFFICIENTE E DALLE DIMENSIONI CONTENUTE, IL PROGRAMMA DI VETRINE VENUS E' UNA NUOVA GRANDE OPPORTUNITÀ PER I TUTTI PROFESSIONISTI DEL FREDDO E DELL'ARREDAMENTO.

DAL DESIGN ELEGANTE E PULITO, VENUS RAPPRESENTA UN FELICE CONNUBIO TRA SOSTANZA E FORMA. VERSATILE, EFFICIENTE E DALLE DIMENSIONI CONTENUTE, IL PROGRAMMA DI VETRINE VENUS E' UNA NUOVA GRANDE OPPORTUNITÀ PER I TUTTI PROFESSIONISTI DEL FREDDO E DELL'ARREDAMENTO.

DAL DESIGN ELEGANTE E PULITO, VENUS RAPPRESENTA UN FELICE CONNUBIO TRA SOSTANZA E FORMA. VERSATILE, EFFICIENTE E DALLE DIMENSIONI CONTENUTE, IL PROGRAMMA DI VETRINE VENUS E' UNA NUOVA GRANDE OPPORTUNITÀ PER I TUTTI PROFESSIONISTI DEL FREDDO E DELL'ARREDAMENTO.



VENUS NEUTRO PANE

CARATTERISTICA N.1 - STRINGA DI TESTO

CARATTERISTICA N.2 - STRINGA DI TESTO

CARATTERISTICA N.3 - STRINGA DI TESTO

CARATTERISTICA N.4 - STRINGA DI TESTO

CARATTERISTICA N.5 - STRINGA DI TESTO

CARATTERISTICA N.6 - STRINGA DI TESTO

VENUS TAVOLA CALDA

CARATTERISTICA N.1 - STRINGA DI TESTO

CARATTERISTICA N.2 - STRINGA DI TESTO

CARATTERISTICA N.3 - STRINGA DI TESTO

CARATTERISTICA N.4 - STRINGA DI TESTO

CARATTERISTICA N.5 - STRINGA DI TESTO

CARATTERISTICA N.6 - STRINGA DI TESTO





VENUS DOLCI E CIOCCOLATO

CARATTERISTICA N.1 - STRINGA DI TESTO

CARATTERISTICA N.2 - STRINGA DI TESTO

CARATTERISTICA N.3 - STRINGA DI TESTO

CARATTERISTICA N.4 - STRINGA DI TESTO

CARATTERISTICA N.5 - STRINGA DI TESTO

CARATTERISTICA N.6 - STRINGA DI TESTO

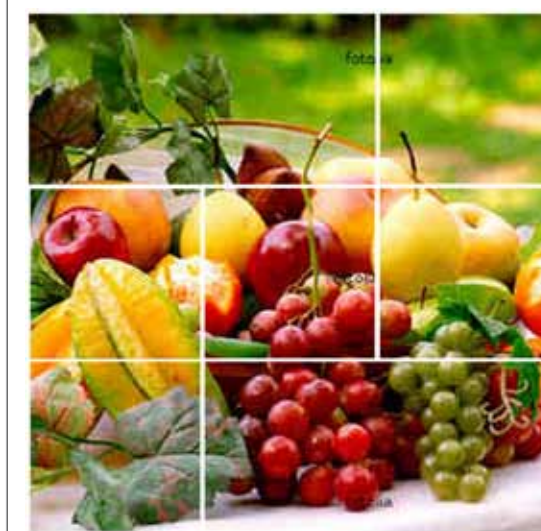

VENUS MACEDONIE E CREPES

CARATTERISTICA N.1 - STRINGA DI TESTO

CARATTERISTICA N.2 - STRINGA DI TESTO

CARATTERISTICA N.3 - STRINGA DI TESTO

CARATTERISTICA N.4 - STRINGA DI TESTO

CARATTERISTICA N.5 - STRINGA DI TESTO

CARATTERISTICA N.6 - STRINGA DI TESTO





VENUS BQ P859

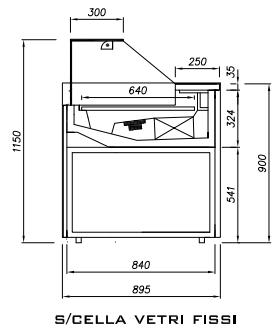

S/CELLA VETRI FISSI

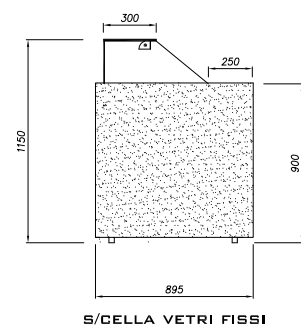

S/CELLA VETRI FISSI

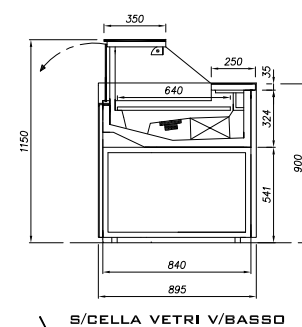

S/CELLA VETRI V/BASSO

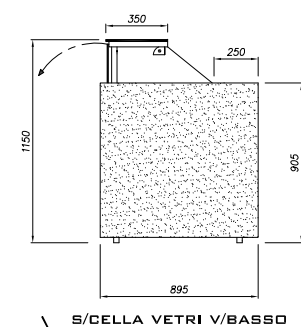

S/CELLA VETRI V/BASSO

VENUS P985

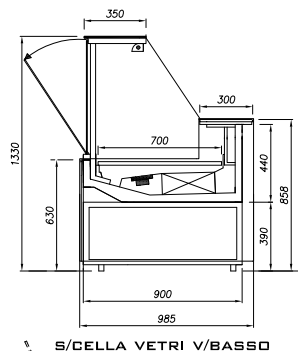

S/CELLA VETRI V/BASSO

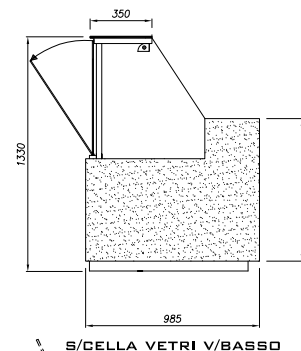

S/CELLA VETRI V/BASSO

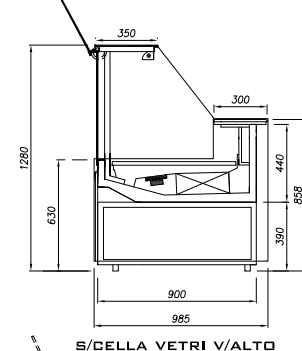

S/CELLA VETRI V/ALTO

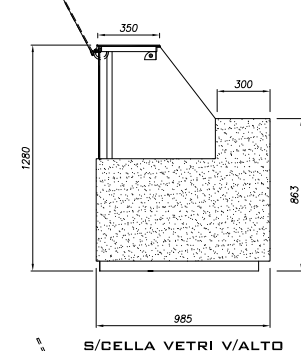

S/CELLA VETRI V/ALTO

**VENUS LB P1100
VETRI VERSO L'ALTO**

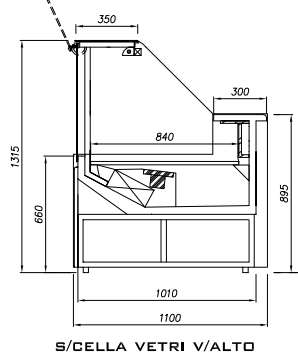

S/CELLA VETRI V/ALTO

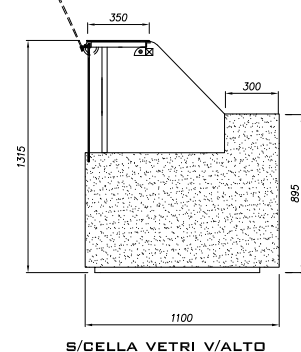

S/CELLA VETRI V/ALTO

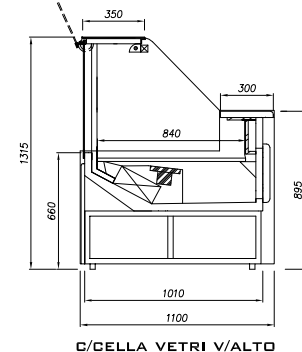

C/CELLA VETRI V/ALTO

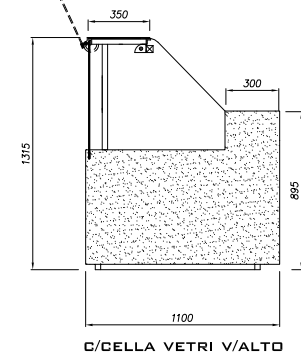

C/CELLA VETRI V/ALTO

**VENUS LB P1100
VETRI VERSO IL BASSO**

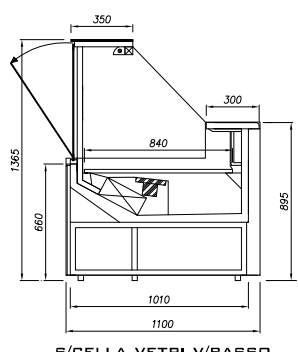

S/CELLA VETRI V/BASSO

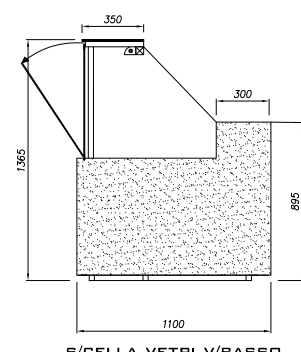

S/CELLA VETRI V/BASSO

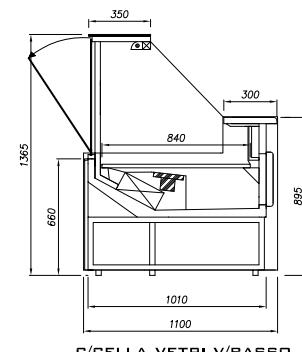

C/CELLA VETRI V/BASSO

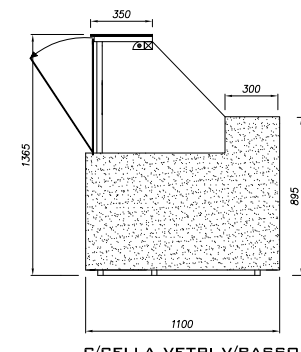

C/CELLA VETRI V/BASSO

ANGOLI ED INGOMBRI DI:
- VENUS BQ P859
- VENUS P985

ANGOLO INTERNO 90°
DIAGONALE

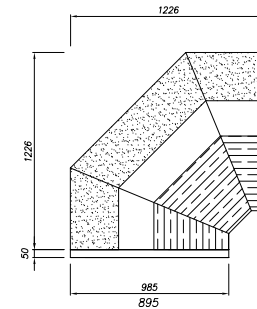

ANGOLO INTERNO 90°
SQUADRATO

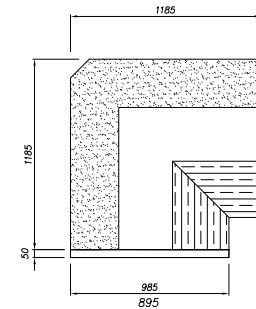

ANGOLO INTERNO 135°

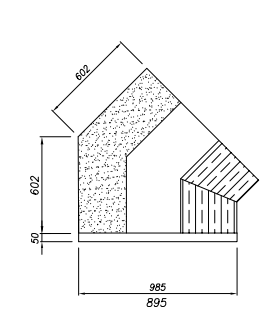

ANGOLO ESTERNO 90°

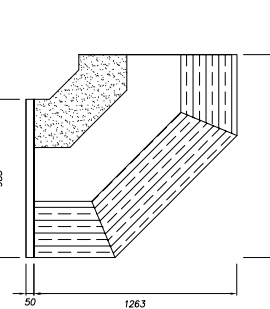

ANGOLO ESTERNO 135°

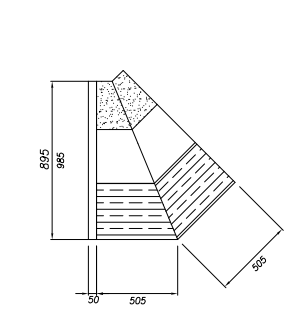

ANGOLI ED INGOMBRI DI:
- VENUS LB-LBR V/ALTO
- VENUS LB-LBR V/BASSO

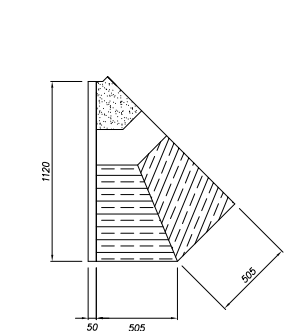
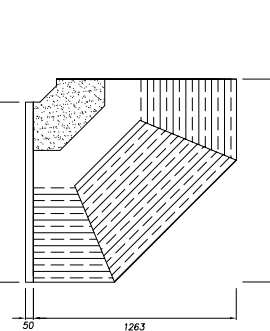
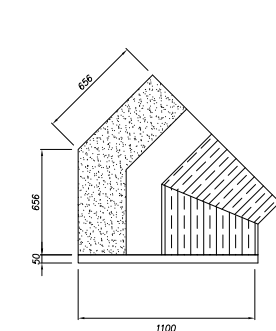
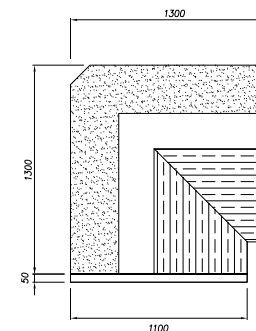
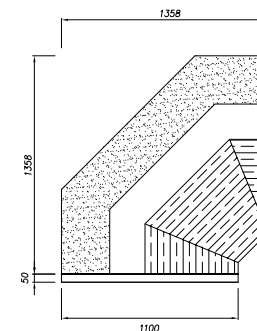

DATI TECNICI	UNITÀ	VENUS BQ				VENUS P985			VENUS LB-LBR						VENUS				
		L1	L2	L3	L4	L1	L2	L3	L1	L2	L3	L5	L6	L1	L2	L3	L4	L5	
LUNGHEZZA SENZA SPALLA LENGHT WITHOUT ENDS TEDESCO	MM	950	1400	1900	2400	2800	950	1400	1900	2800	3400	1900	2000	5000	6000	7000	3500	2500	
POTENZA FRIGORIFERA REFRIGERATION POWER TEDESCO	W	709	1160	1374	1650	1650	709	116	1374	1650	3050	4020	4080	1300	1250	1200	895	300	
POTENZA NOMINALE RATED POWER TEDESCO	W	709	1160	1374	1650	1650	709	116	1374	1650	3050	4020	4080	1508	1350	1208	1250	0123	
SPORTELLI RISERVA DOORS TEDESCO	QT.	1	2	2	4	5	1	2	2	5	2	4	5	0	1	2	5	7	
AREA ESPOSITIVA REFRIGERATA COOLED DISPLAY AREA TEDESCO	MQ	0.78	1.15	1.56	1.97	2.3	0.7	1.56	2.3	1.56	2.3	3.5	4.2	4.8	6.5	3.8	2.5	9.0	





VIA DEL PIANO S.N.
61022 TALACCHIO
DI COLBORDOLO
PESARO
ITALY
TEL. 0721.478443
FAX. 0721.479306



INFO@TECNOBANC.IT

WEB:

TECNOBANC.IT

TECNOBANC.COM

TECNOBANC-AUSTRIA.AT



V E N U S M A K E U P







DATI TECNICI	UNITÀ	VENUS BQ				VENUS P985			VENUS LB-LBR						VENUS				
		L1	L2	L3	L4	L1	L2	L3	L1	L2	L3	L5	L6	L1	L2	L3	L4	L5	
LUNGHEZZA SENZA SPALLA LENGHT WITHOUT ENDS TEDESCO	MM	950	1400	1900	2400	2800	950	1400	1900	2800	3400	1900	2000	5000	6000	7000	3500	250	
POTENZA FRIGORIFERA REFRIGERATION POWER TEDESCO	W	709	1160	1374	1650	1650	709	116	1374	1650	3050	4020	4080	1300	1250	1200	895	300	
POTENZA NOMINALE RATED POWER TEDESCO	W	709	1160	1374	1650	1650	709	116	1374	1650	3050	4020	4080	1508	1350	1208	1250	0123	
SPORTELLI RISERVA DOORS TEDESCO	QT.	1	2	2	4	5	1	2	2	5	2	4	5	0	1	2	5	7	
AREA ESPOSITIVA REFRIGERATA COOLED DISPLAY AREA TEDESCO	MQ	0.78	1.15	1.56	1.97	2.3	0.7	1.56	2.3	1.56	2.3	3.5	4.2	4.8	6.5	3.8	2.5	9.0	